

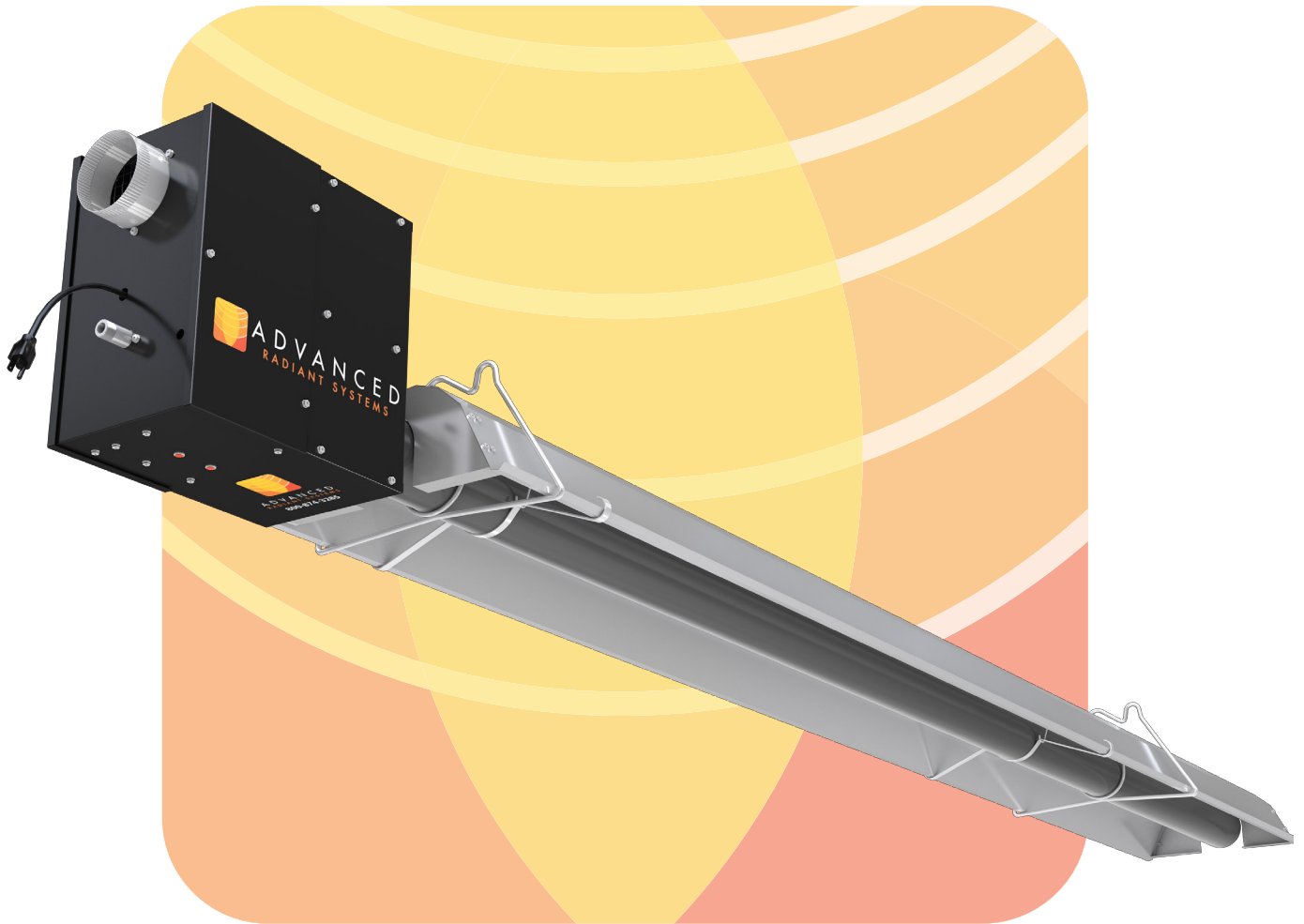

# ADVANCED RADIANT SYSTEMS

## Installation, Operation and Service Instructions



### ES/ESH RANGE SINGLE STAGE INFRARED HEATERS





# WARNINGS

## WARNING

Improper installation, adjustment, alteration, service or maintenance can cause property damage, injury or death. Read the installation, operating and maintenance instructions thoroughly before installing or servicing this equipment.

## FOR YOUR SAFETY

Do not store or use gasoline or other flammable vapors and liquids in the vicinity of this or any other appliance. If you smell gas:

1. Open windows
2. Don't touch electrical switches
3. Extinguish any open flame
4. Immediately call your gas supplier

## OWNER

Retain this Manual & ensure available for service. Improper installation, adjustment, alteration, service or maintenance can cause injury, death or property damage.

Read the installation, operation and service instructions thoroughly before installing or servicing this equipment.

## INSTALLER

Provide Manual to Owner upon completion of installation!

Read and thoroughly understand these Instructions before attempting any installation

## CAUTION: FIRE OR EXPLOSION HAZARD

Maintain clearance to combustible constructions as further specified in this manual. Failure to do so could result in a serious fire hazard. Heaters should not be located in hazardous atmospheres containing flammable vapors or combustible dusts. Signs should be provided in storage areas specifying maximum safe stacking height.

## CAUTION: MECHANICAL HAZARD

This equipment expands and contracts with each operating cycle. The gas connection, suspension hardware and the installation itself must safely allow this movement. Failure to do so could result in serious fire or explosion hazard.

## CAUTION: FIRE OR EXPLOSION HAZARD

This heater is equipped with an automatic ignition device. Do not attempt to light the burner by hand. Failure to comply could result in a serious fire and personal injury hazard.

## CAUTION: MECHANICAL HAZARD

Do not use high pressure (above 1/2 psi) to test the gas supply system with the burners connected, doing so could result in damage to the burner and its control components requiring replacement.

## CAUTION: SERVICE LIFE RISK

Do not install equipment in atmospheres containing halogenated hydrocarbons or other corrosive chemicals, doing so may lead to premature equipment failure and invalidation of the warranty. Additionally, it is recommended that the equipment be installed with a slope downward and away from the burner of 1/4" (6mm) in 10' (3m) to allow start-up condensate drainage.

# CONTENTS

<b>INTRODUCTION</b> .....	<b>1</b>
Installation Codes.....	1
<b>GENERAL SPECIFICATIONS</b> .....	<b>2</b>
<b>DIMENSIONAL CHARTS</b> .....	<b>3</b>
Baffle Kit Parts Reference .....	4
*Additional Approved Special Configurations .....	4
<b>CLEARANCE TO COMBUSTIBLES</b> .....	<b>6</b>
<b>INSTALLATION</b> .....	<b>9</b>
Installation Sequence.....	9
Overview of Tubes and Reflector Hangers .....	10
Hangers Installation and Heater Suspension.....	11
Tube Installation .....	12
Heater and Baffle Installation.....	14
Reflector Installation .....	16
Elbow and U-Bend Installation.....	19
Mitered Reflector Installation .....	20
Side Reflectors & Bottom Shields .....	21
Bottom Shield Reflector Installation .....	22
Decorative Grille (Optional).....	23
<b>VENTING AND COMBUSTION AIR DUCTING</b> .....	<b>24</b>
General Requirements .....	24
Un-Vented Operation.....	24
Vented Operation.....	25
Horizontal Venting.....	25
Common Horizontal Venting .....	26
Vertical Venting .....	27
Common Vertical Venting.....	27
Combustion Air Supply (Optional).....	28
Outdoor Installation (ESH MODELS ONLY) .....	29
<b>GAS PIPING</b> .....	<b>30</b>
General Requirements .....	30
<b>ELECTRICAL WIRING</b> .....	<b>30</b>
General Requirements .....	30
Wiring Diagrams .....	31
Wiring Diagram for ESH Models Only .....	32
<b>BURNER OPERATION</b> .....	<b>33</b>
Starting Sequence of Operation.....	33
Maintenance .....	33
<b>INSTALLATION CHECKLIST</b> .....	<b>34</b>
<b>TROUBLESHOOTING</b> .....	<b>35</b>
Module Codes.....	35
Troubleshooting Chart .....	36
<b>REPLACEMENT PARTS</b> .....	<b>37</b>
<b>WARRANTY</b> .....	<b>38</b>

Advanced Radiant Systems' Economy Range (ES) offers an entry grade unitary system with the highest radiant outputs available. By utilizing a high efficiency reflector with a dependable and efficient burner, these heaters take on the cost competitive marketplace without sacrificing quality or efficiency. The Economy Range is also available in a harsh environment model. The ESH model will tackle those areas where conditions are at their most demanding.

## IMPORTANT

These instructions, the layout drawing, local codes and ordinances, and applicable standards such as apply to gas piping and electrical wiring comprise the basic information needed to complete the installation, and must be thoroughly understood along with general building codes before proceeding.

Only personnel who have been trained and understand all applicable codes should undertake the installation. Representatives that are Factory Certified in the service and application of this equipment and can be called on for helpful suggestions about installation.

## Installation Codes

Installations must comply with local building codes, or in their absence, the latest edition of the national regulations and procedures as listed below.

### General Installation and Gas Codes

Heaters must be installed only for use with the type of gas appearing on the rating plate, and the installation must conform to the National Fuel Gas Code, ANSI Z223.1/NFPA 54 in the US and CSA B149.1 and B149.2 Installation Codes in Canada.

This heater maybe approved for either indoor or outdoor installation. Not for use in residential dwellings, refer to Rating plate.

### Aircraft Hangar Installation

Installation in aircraft hangars must conform to the Standard for Aircraft Hangars, ANSI/NFPA 409 in the US and CSA B149.1 and B149.2 Installation Codes in Canada.

### Public Garage Installation

Installation in public garages must conform to the Standard for Parking Structures, NFPA-88A or Standard for Repair Garages, NFPA 88B, in the US and CSA B149.1 and B149.2 Installation Codes in Canada.

### Parking Structures

Technical requirements are outlined in ANSI/NFPA 88B (USA)

### Gas Supply Lines

Gas supply pipe sizing must be in accordance with the National Fuel Gas Code, ANSI Z223.1/NFPA 54 in the US and CSA B149.1 and B149.2 Installation Codes in Canada.

A 1/8 in NPT plugged tap must be installed in the gas line connection immediately upstream of the burner farthest from the gas supply meter to allow checking of system gas pressure.

### Electrical

All heaters must be electrically grounded in accordance with the National Electric Code, ANSI/NFPA 70 in the US, and the Canadian Electric Code, CSA C22.1 in Canada, and must comply with all local requirements.

### Venting

Refer to the National Fuel Gas Code, ANSI Z223.1 (NFPA 54) in the US and CSA B149.1 and B149.2 Installation Codes in Canada, as well as all local requirements for general venting guidance.

# GENERAL SPECIFICATIONS

## Gas Supply

### Inlet Pressure

Natural Gas: Minimum 5.0" W.C.  
Maximum 14.0" W.C.

Propane Gas: Minimum 11.5" W.C.  
Maximum 14.0" W.C.

### Manifold Pressure

Natural Gas: 3.5" W.C. Propane Gas: 10.00" W.C.

### Inlet Connection

Natural Gas or Propane: 1/2" NPT

## Electric Supply

120 VAC, 60 HZ, 1 Amp: 36" cord with grounded 3 prong plug

## Flue and Outside Air Connection

4" O.D. connection for flue adapter and outside air (optional) provided at the heater

# DIMENSIONAL CHARTS

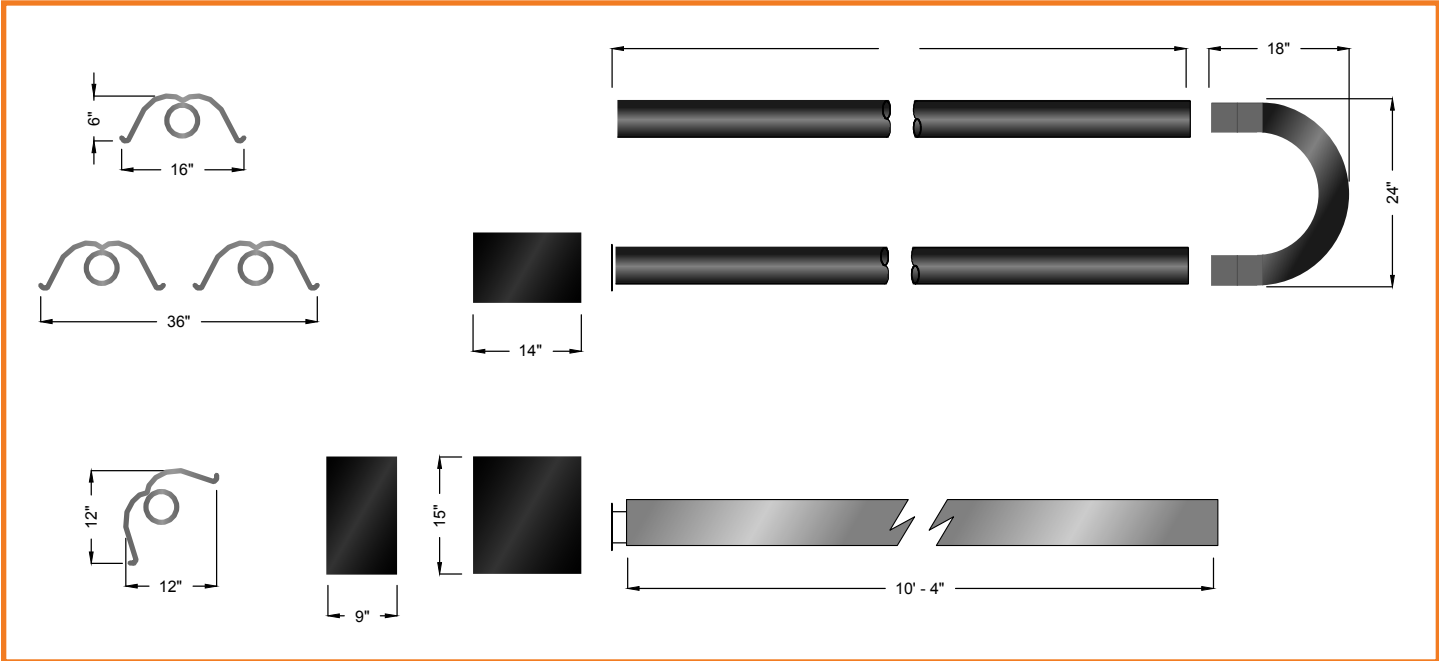

Figure 1: Overall Dimensional Information

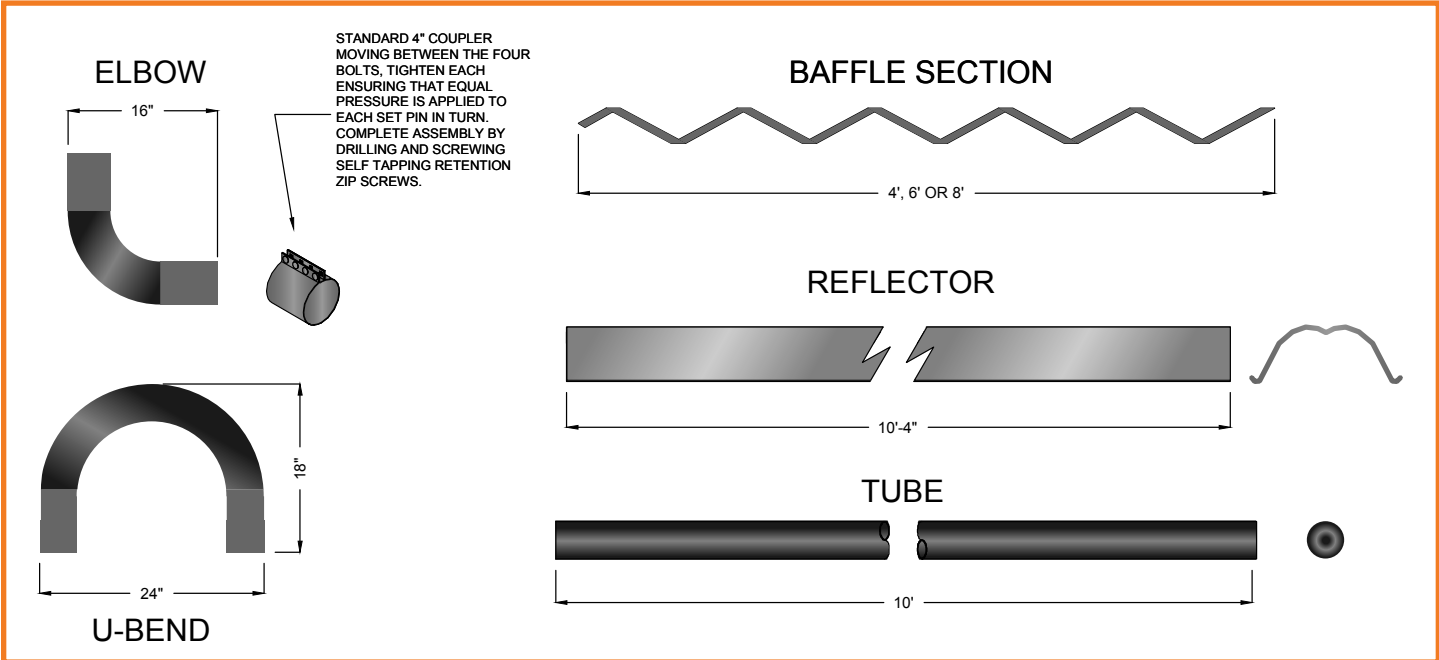

Figure 2: Component Dimensional Information

# CONFIGURATIONS

Model	Rate (BTU/Hr)	Heat Exchanger Length ft (m)		Baffle ft (m)	Baffle Kit Part No.
		Minimum	Maximum		
ES/ESH-40	40,000	10 (3)	20 (6)	6 (1.8)	R-CT045
ES/ESH-60*	60,000	20 (6)	30 (9)	6 (1.8)	R-CT046
ES/ESH-80*	80,000	20 (6)	30 (9)	12 (36)	R-CT047
ES/ESH-100*	100,000	20 (6)	30 (9)	12 (36)	R-CT047
ES/ESH-125*	125,000	30 (9)	50 (12)	12 (36)	R-CT047
ES/ESH-150*	150,000	40 (12)	60 (18)	6 (1.8)	R-CT046
ES/ESH-175	175,000	50 (15)	60 (18)		
ES/ESH-205*	205,000	60 (18)	70 (21)		
ES/ESH-220	220,000	60 (18)	70 (21)		

\* Special configurations available - see below

Table 1: Configuration Information

## Note:

- Baffles are always placed in the last section of radiant tube.
- Baffles are either aluminized or stainless steel sections 6' long.
- When only 6' is required an aluminized steel baffle is installed, except on the ES/ESH-40 where a special 6' stainless steel baffle with a red identification tab must be installed.
- When 12' is required, a 6' stainless steel baffle is inserted first into the end tube followed by another 6' aluminized baffle. The stainless steel baffle is now closest to the burner.

## Baffle Kit Parts Reference

- R-CT045 ES/ESH-40,000 BTU/hr only, 6' long, stainless steel w/ red identification tab.
- R-CT046 6' long, aluminized steel
- R-CT047 Baffle Kit, 12' long aluminized & stainless steel.
- R-CT095 ES/ESH-205,000 BTU/hr – 50 ft ONLY

## \*Additional Approved Special Configurations

- 60,000 BTU/Hr 15' heat exchanger with 6' Stainless steel baffle with red tab (Natural Gas Only)
- 80,000 BTU/Hr 40' heat exchanger with NO baffle or 6' aluminized baffle.
- 100,000 BTU/Hr 40' or 50' heat exchanger with NO baffle or 6' aluminized baffle
- 125,000 BTU/Hr 40' or 50' heat exchanger with 6' aluminized baffle
- 150,000 BTU/Hr 60' heat exchanger with NO baffle
- 205,000 BTU/Hr 50' heat exchanger with a 4' baffle at 40', and a 8' baffle at 50'. (See figure 3)

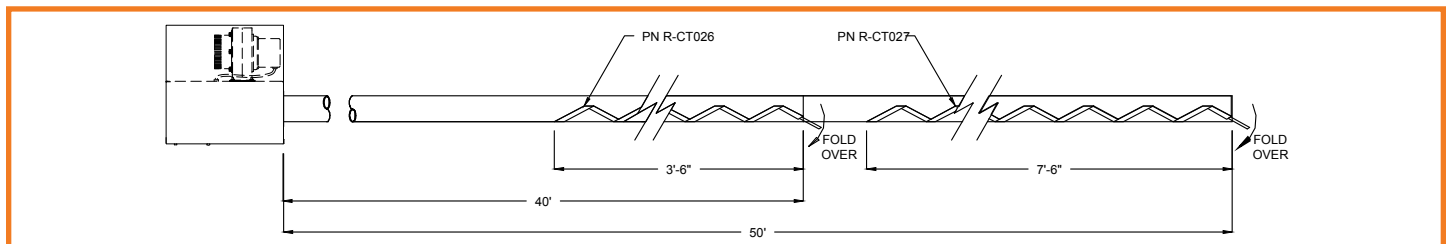

Figure 3: Baffle location for all ES/ESH-205, 50ft models ONLY (PN R-CT095 Baffle Kit)



# CONFIGURATIONS

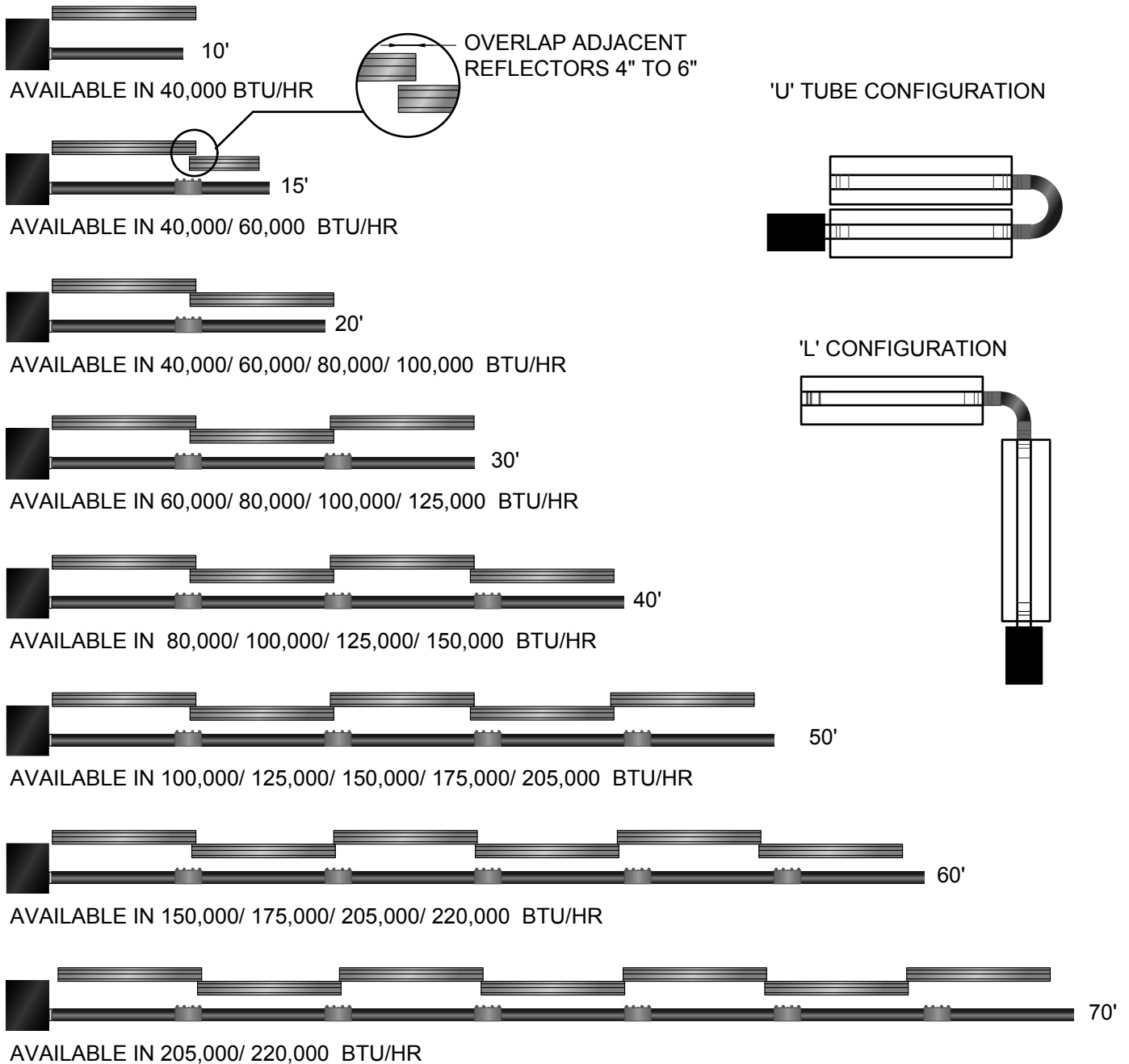
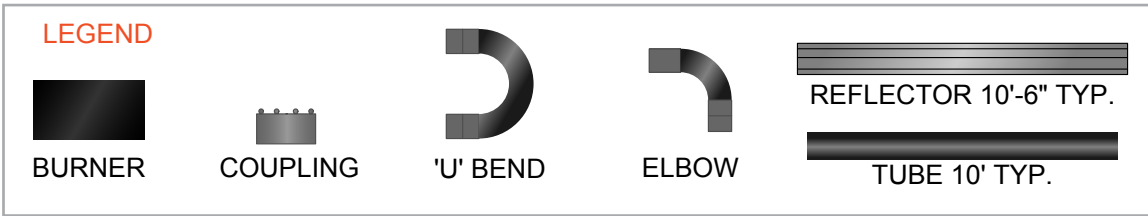

Figure 4: Typical Configurations. Not To Scale

# CLEARANCE TO COMBUSTIBLES

A general clearance of 18 in (46 cm) in every direction is recommended for servicing.

In addition to this it is very important to observe the minimum clearance to combustibles at all times to avoid any possibility of property damage or personal injury.

## WARNING

- Clearances as marked on the heater body must be maintained from vehicles parked beneath. Signs should be posted identifying any possible violation of the clearance distances from the heater in all vehicle areas.
- Maximum allowable stacking height in storage areas should be identified with signs or appropriate markings adjacent to the thermostat or in a conspicuous location.

Table 2 lists the minimum clearance to combustible materials for various installation configurations. Note that standard clearances also apply to installation above T-bar ceilings and above decorative grills. Additional clearance may be required for glass, painted surfaces and other materials which may be damaged by radiant or convective heat.

**Combustible materials** are considered to be wood, compressed paper, plant fibers, plastics, Plexiglas or other materials capable of being ignited and burned. Such materials shall be considered combustible even though flameproofed, fire-retardant treated or plastered.

Reflector miter kits are available for U-bends and elbows.

Adequate clearance to sprinkler heads must be maintained (NFPA 13: Standard for the Installation of Sprinkler Systems).

The stated clearance to combustibles represents a surface temperature of 90°F (32°C) above room temperature. Building materials with low heat tolerance (i.e. plastics, vinyl siding, canvas, tri-ply, etc.) may be subject to degradation at lower temperatures.

**It is the installer's responsibility to ensure that adjacent materials are protected from deterioration.**

- Note 1:** Bottom Shields are approved for all burner sizes. The "below" clearance (dimension C in Table 2) may be reduced by 25% when an approved Bottom Shield is used.
- Note 2:** Reduced clearances downstream from the burner are approved for all configurations. Dimensions "B", "C", and "D" in Table 2 can be reduced for locations 25' (7.6 m) or more downstream from a burner, before the next burner, maximum reduction is 50%

Reflector Configurations	Model Number	Clearance to Combustibles in (cm)			
		A	B	C	D
<b>HORIZONTAL</b>					
	ES/ESH-40	2 (5)	18 (46)	45 (114)	18 (46)
	ES/ESH-60	2 (5)	25 (63)	58 (147)	25 (63)
	ES/ESH-80	2 (5)	26 (66)	62 (157)	26 (66)
	ES/ESH-100	2 (5)	30 (76)	67 (170)	30 (76)
	ES/ESH-125	4 (10)	33 (84)	71 (180)	33 (84)
	ES/ESH-150	4 (10)	36 (91)	74 (188)	36 (91)
	ES/ESH-175	6 (15)	40 (102)	78 (198)	40 (102)
	ES/ESH-205	6 (15)	44 (46)	80 (203)	44 (46)
	ES/ESH-220	6 (15)	46 (117)	83 (211)	46 (117)

Table 2: Minimum Clearance to Combustibles (pp. 6-8)

# CLEARANCE TO COMBUSTIBLES

Reflector Configurations	Model Number	Clearance to Combustibles in (cm)			
		A	B	C	D
<b>HORIZONTAL</b>					
	ES/ESH-40	4 (10)	4 (10)	40 (102)	38 (97)
	ES/ESH-60	4 (10)	4 (10)	50 (127)	46 (117)
	ES/ESH-80	4 (10)	4 (10)	58 (147)	50 (127)
	ES/ESH-100	4 (10)	4 (10)	67 (170)	58 (147)
	ES/ESH-125	4 (10)	4 (10)	70 (178)	63 (160)
	ES/ESH-150	4 (10)	4 (10)	71 (180)	64 (163)
	ES/ESH-175	8 (20)	4 (10)	74 (188)	67 (170)
	ES/ESH-205	10 (25)	4 (10)	78 (198)	72 (183)
	ES/ESH-220	10 (25)	4 (10)	81 (205)	77 (196)

ONE SIDE EXTENSION	Model No.	A	B	C	D
	ES/ESH-40	2 (5)	4 (10)	50 (127)	35 (89)
	ES/ESH-60	2 (5)	4 (10)	58 (147)	38 (97)
	ES/ESH-80	2 (5)	4 (10)	63 (160)	42 (107)
	ES/ESH-100	2 (5)	4 (10)	73 (185)	45 (114)
	ES/ESH-125	4 (10)	4 (10)	76 (193)	50 (127)
	ES/ESH-150	4 (10)	4 (10)	78 (198)	52 (132)
	ES/ESH-175	6 (15)	6 (15)	80 (203)	54 (137)
	ES/ESH-205	6 (15)	6 (15)	84 (213)	56 (142)
	ES/ESH-220	6 (15)	6 (15)	84 (213)	58 (147)

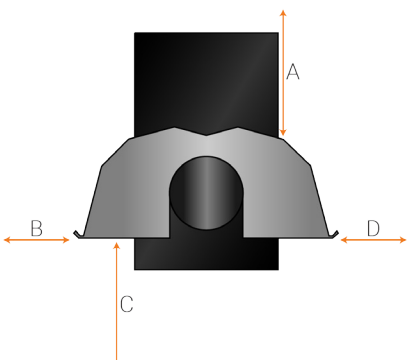
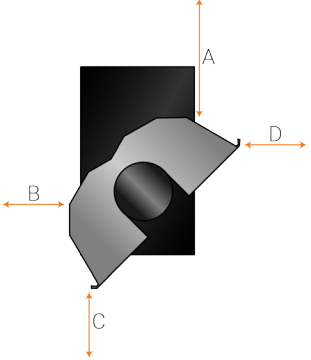
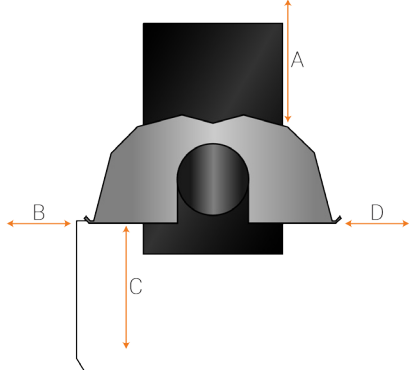
TWO SIDE EXTENSIONS	Model No.	A	B	C	D
	ES/ESH-40	2 (5)	9 (23)	50 (127)	18 (46)
	ES/ESH-60	2 (5)	16 (41)	58 (147)	25 (63)
	ES/ESH-80	2 (5)	18 (46)	64 (163)	26 (66)
	ES/ESH-100	4 (10)	18 (46)	71 (180)	30 (76)
	ES/ESH-125	4 (10)	22 (56)	78 (198)	33 (84)
	ES/ESH-150	4 (10)	24 (64)	80 (203)	36 (91)
	ES/ESH-175	6 (15)	26 (66)	82 (208)	40 (102)
	ES/ESH-205	6 (15)	29 (74)	86 (218)	44 (46)
	ES/ESH-220	6 (15)	31 (79)	88 (224)	46 (117)

Table 2: Minimum Clearance to Combustibles (pp. 6-8)

# CLEARANCE TO COMBUSTIBLES

Reflector Configurations	Model Number	Clearance to Combustibles in (cm)			
		A	B	C	D
<b>U-BEND, HORIZONTAL</b>					
	ES/ESH-40	-	-	-	-
	ES/ESH-60	2 (5)	25 (63)	59 (150)	22 (56)
	ES/ESH-80	2 (5)	28 (71)	62 (157)	26 (66)
	ES/ESH-100	2 (5)	30 (76)	71 (180)	30 (76)
	ES/ESH-125	4 (10)	34 (86)	74 (188)	33 (66)
	ES/ESH-150	4 (10)	37 (94)	76 (193)	36 (84)
	ES/ESH-175	6 (15)	40 (102)	78 (198)	40 (102)
	ES/ESH-205	6 (15)	45 (114)	82 (208)	44 (112)
	ES/ESH-220	6 (15)	46 (117)	88 (224)	46 (117)

Reflector Configurations	Model No.	A	B	C	D
<b>U-BEND, OPPOSITE 45°</b>					
	ES/ESH-40	-	-	-	-
	ES/ESH-60	4 (10)	46 (117)	51 (129)	16 (41)
	ES/ESH-80	4 (10)	50 (127)	54 (137)	18 (46)
	ES/ESH-100	4 (10)	54 (137)	64 (163)	18 (46)
	ES/ESH-125	4 (10)	63 (160)	69 (175)	22 (56)
	ES/ESH-150	4 (10)	64 (163)	71 (180)	24 (64)
	ES/ESH-175	8 (20)	67 (170)	74 (188)	26 (66)
	ES/ESH-205	10 (25)	72 (183)	78 (198)	29 (74)
	ES/ESH-220	10 (25)	74 (188)	81 (206)	32 (81)

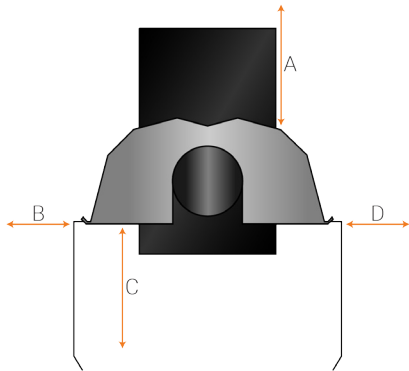
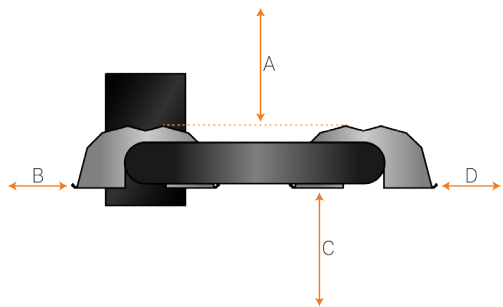
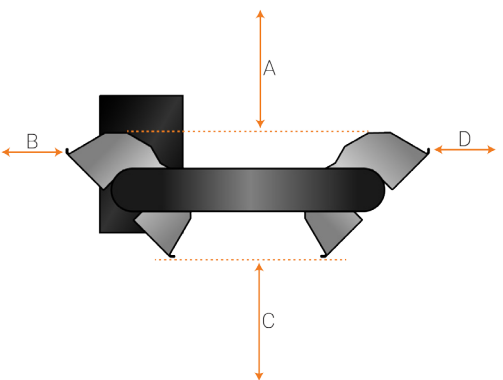
Model No.	Unvented Flue in (cm)		Vented Flue in (cm)
	ABOVE	END	END
ES/ESH-40	12 (30)	26 (66)	18 (46)
ES/ESH-60	12 (30)	26 (66)	18 (46)
ES/ESH-80	18 (46)	26 (66)	18 (46)
ES/ESH-100	18 (46)	26 (66)	18 (46)
ES/ESH-125	18 (46)	32 (81)	18 (46)
ES/ESH-150	18 (46)	32 (81)	18 (46)
ES/ESH-175	18 (46)	32 (81)	18 (46)
ES/ESH-205	18 (46)	32 (81)	18 (46)
ES/ESH-220	18 (46)	32 (81)	18 (46)

Table 2: Minimum Clearance to Combustibles (pp. 6-8)

**Note: All dimensions shown are measured from outside surface of all tubes, reflectors and fittings.**

## Installation Sequence

Generally, there is no unique sequence for installation of the burner or heat exchanger. A review of the job site will usually indicate a logical installation order. However, time and expense can be saved if installation is begun at the most critical dimension, watching for interference from overhead doors, cranes, auto lifts etc. Figure 5 provides a general overview of the components utilized in the installation, as well as their general relationship

A general ordered sequence for installation is provided below for reference..

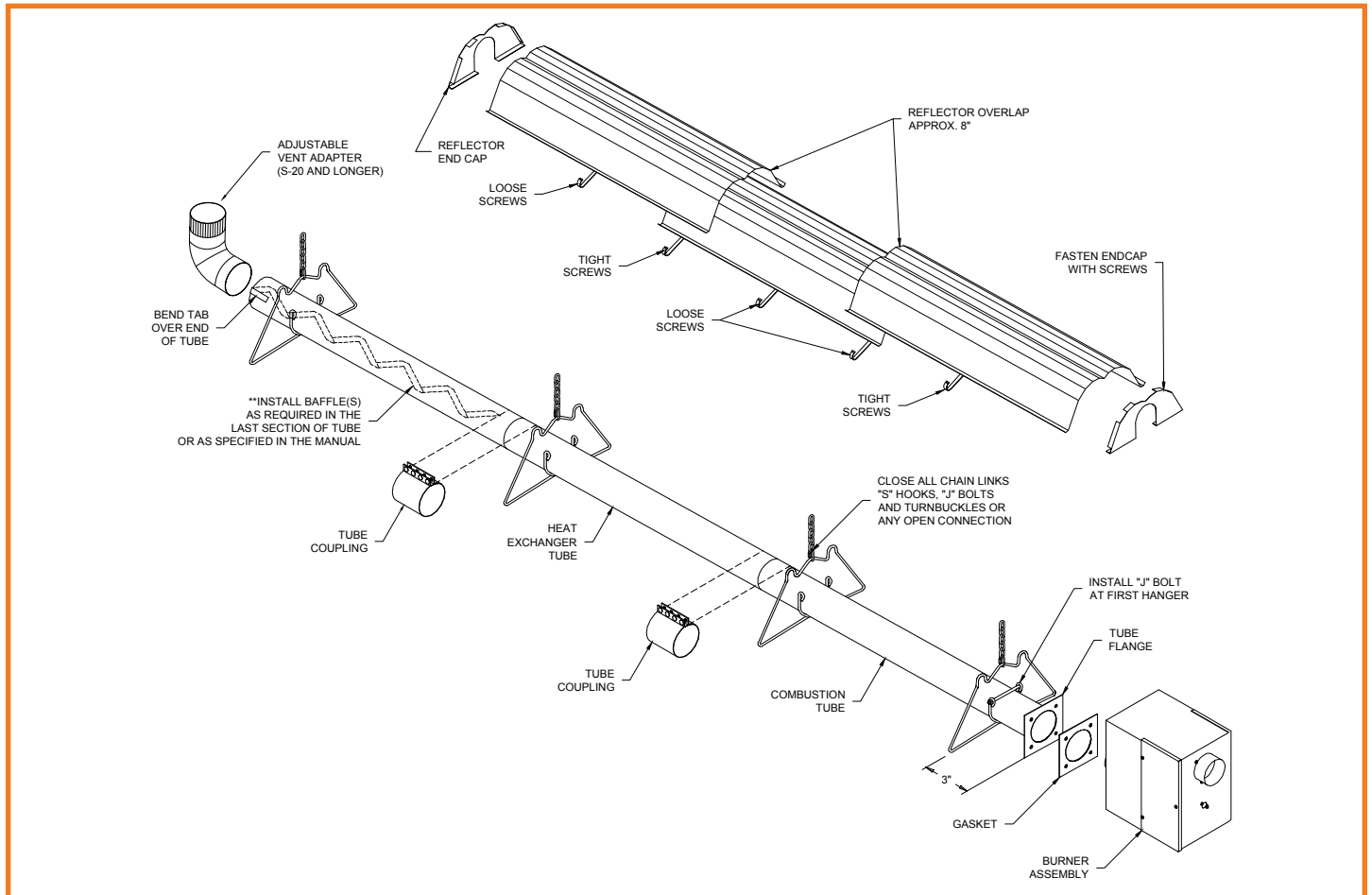

Figure 5: General Overview of Installation

# INSTALLATION

## Overview of Tubes and Reflector Hangers

A general overall view of the tubes and reflector hangers are shown in figure 6 below.

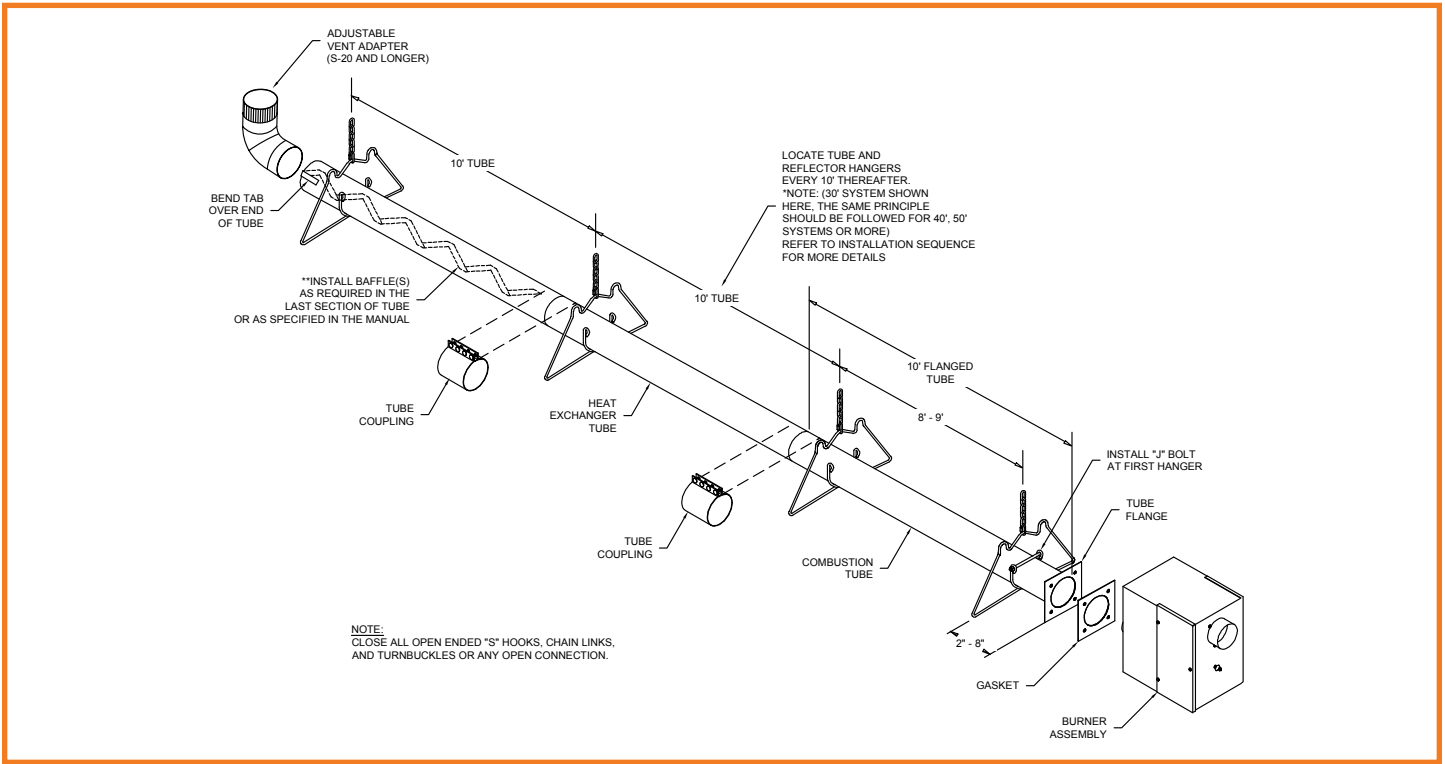

Figure 6: Overview of Tubes and Reflector Hangers

## Hangers Installation and Heater Suspension

- The suspension mechanism must allow for lateral tubing expansion. A minimum 12" length welded link chain with a working load limit of at least 200 lbs. is recommended (refer to Figure 7 for more details). **Manufacturer recommends and makes available "quick links" for connecting chain. If any open ended "S" hooks and turnbuckles are used, the open ends must be closed to avoid unhooking chain with inadvertent contact.**
- Locate hanging chain at predetermined suspension points in the structure. It is required that the first 2 hangers be about 8' to 9' away. Thereafter, 10' apart on average is acceptable for the remainder of the heat exchanger. At no time should hangers be more than 12' apart, (see Figure 8).
- Install the tube and reflector support hanger on the chain with Quick Links or 'S' hooks refer to Figure 7 & Figure 8.

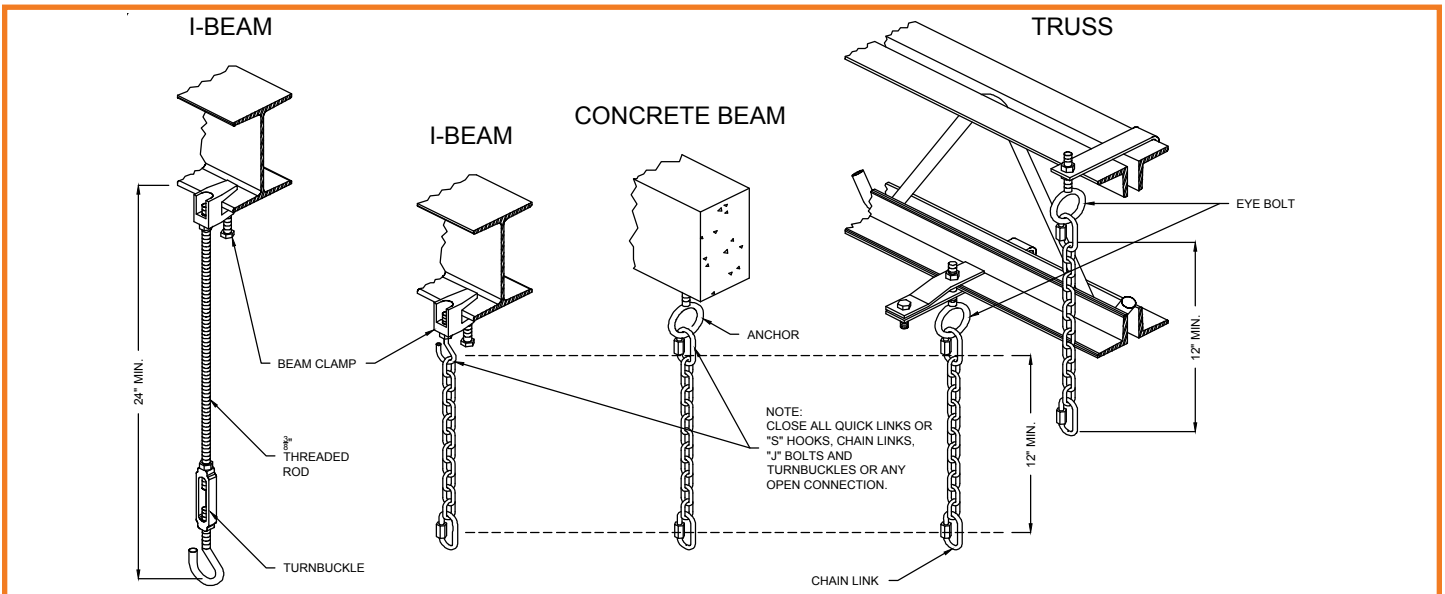

Figure 7: Suspension Mechanism

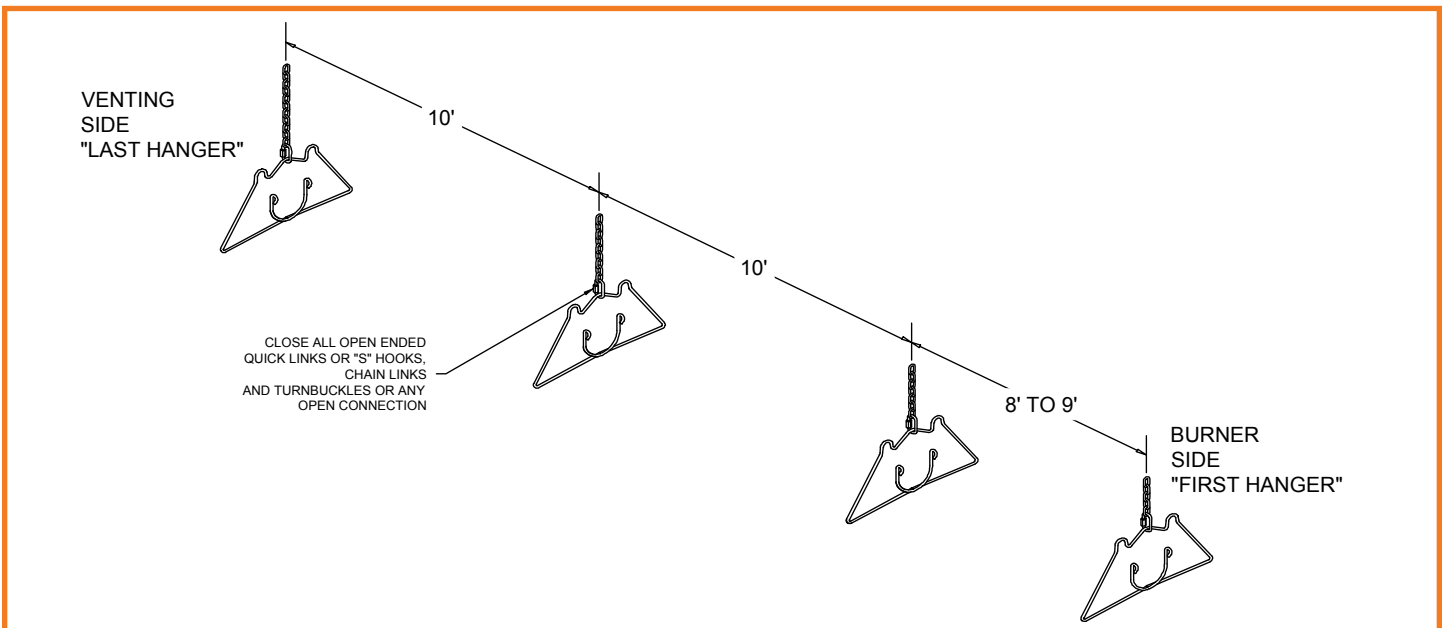

Figure 8: Typical Hanging Points

## Tube Installation

- Place the first (flanged, aluminized) tube in the first two hangers (Figure 9). Be sure the flange is toward the intended burner location. The other end of the tube should have the first coupling already loosely fitted.
- Always use all the hangers supplied. As a rule the combustion tube (first tube) utilizes 2 hangers and thereafter 1 hanger per 10' section. It is required that the first hanging point be 2" to 8" from the burner mounting flange, and tube weld seam must face down, refer to Figure 9 for more details.

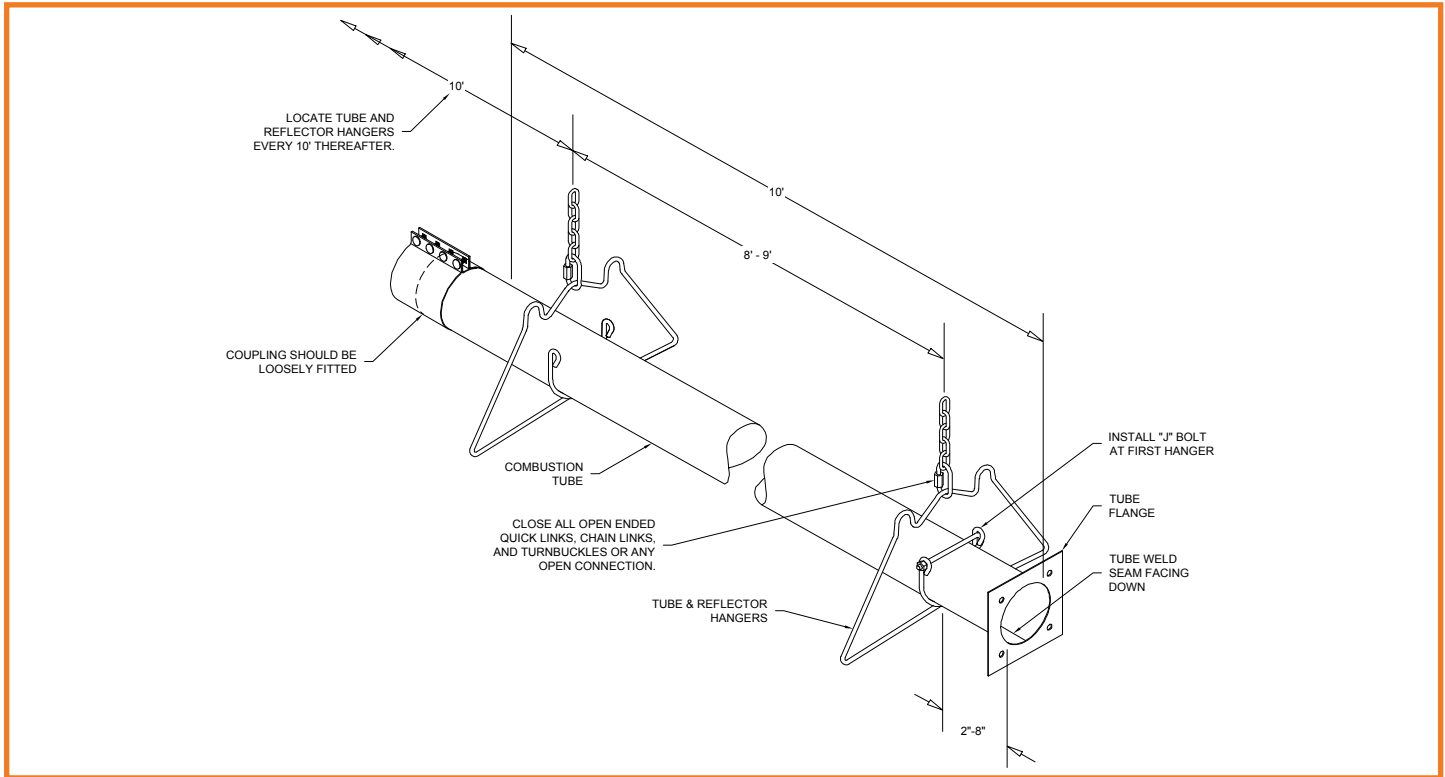

Figure 9: Installation of First Section of Flanged Tube

- For all remaining tubes, fit the end of the tube with a coupling. The coupling should be loose (Figure 10).

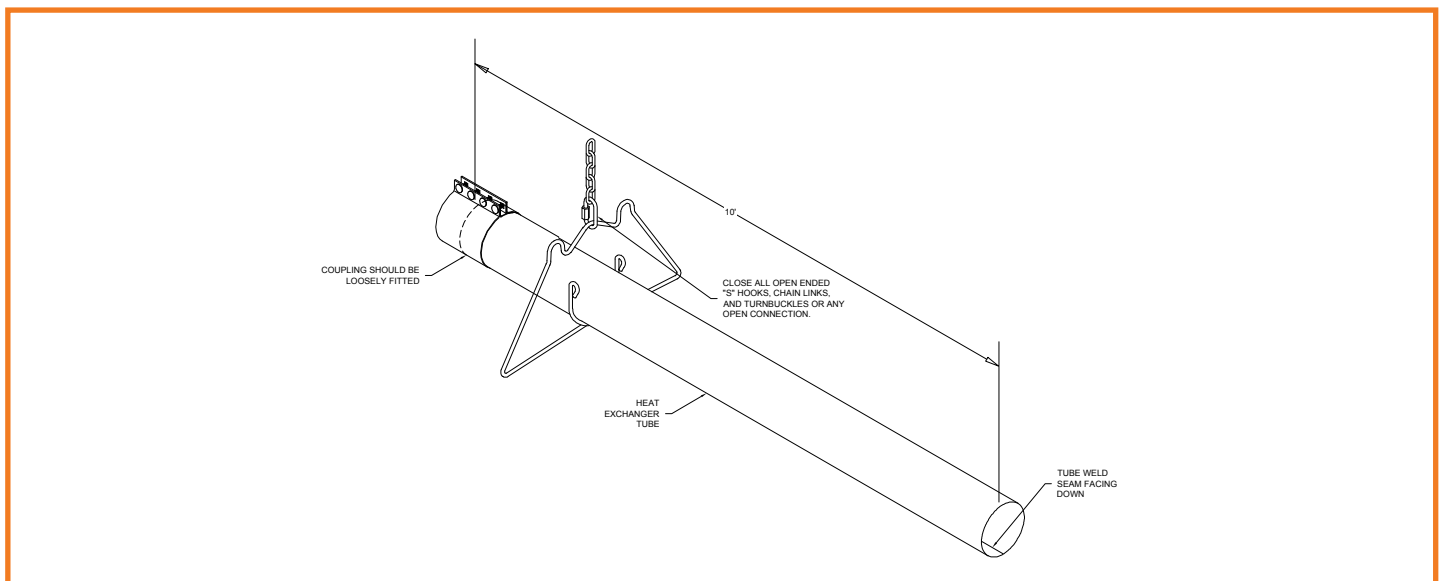

Figure 10: Installation of Heat Exchanger Tube and Coupling



- Tighten the cradle loops of the first hanger with the “J-Bolt” found in the burner box, to snugly hold the combustion tube from rotating see Figure 11.
  - Note:** For all coupling joints, ensure that the tube joint is in the center of the coupling length, and that the overlap joint of the coupling is above the centerline of the tube. Also ensure that the weld seam on ALL tubes is facing down.
  - Note:** In order to obtain smoothly sealed coupling liners, tighten each of the coupling bands progressively and alternately. Tightening one band completely before the other may result in an undesirable wrinkle in the liner (refer to Figure 11).

**DO NOT over torque the coupling. (Torque coupling to 15-25 lb<sub>f</sub>-ft).**

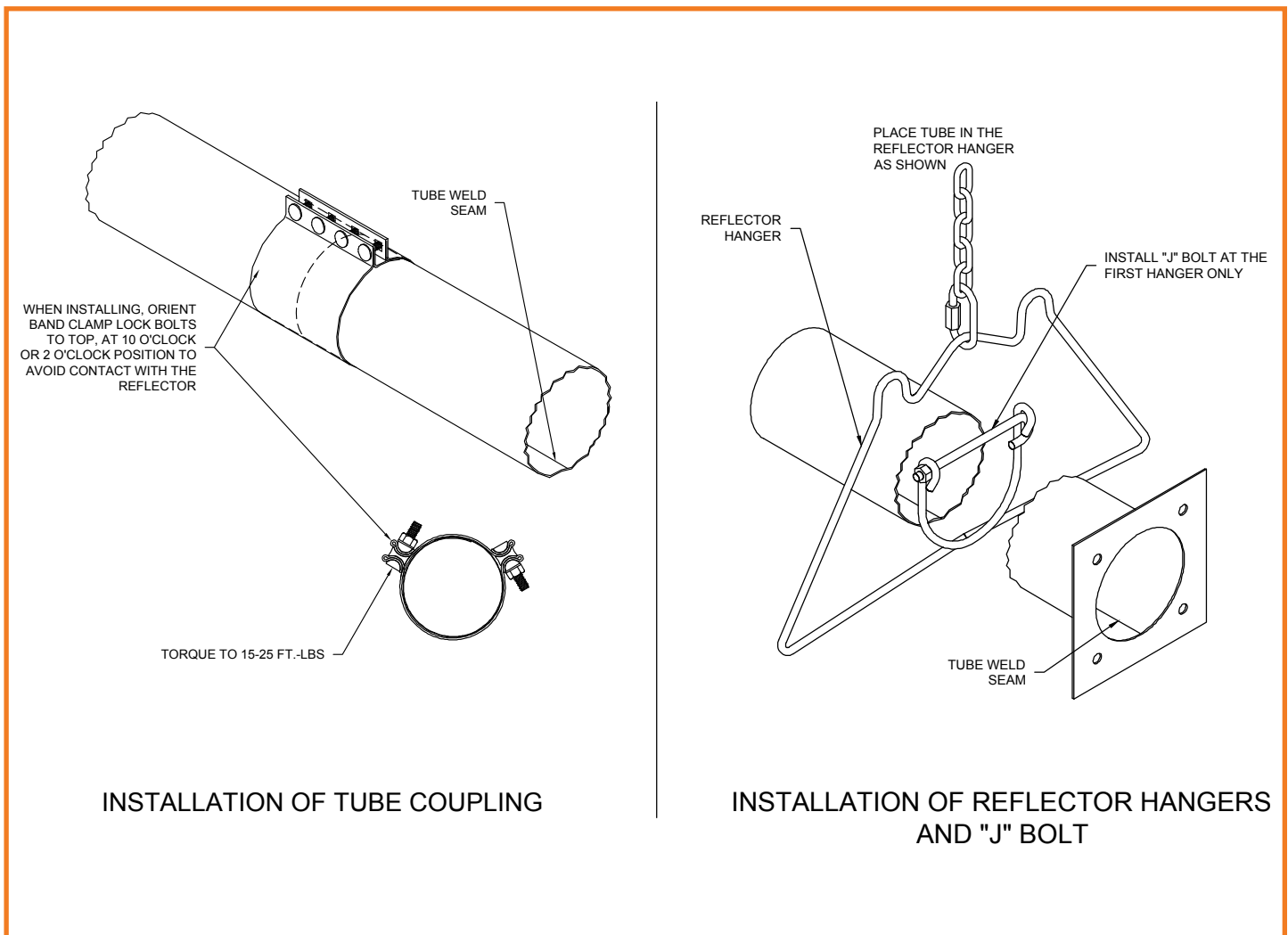

Figure 11: “J” Bolt and Coupling Installations

- Continue placing tubes, couplings and reflectors to complete the heater assembly. Ensure heat exchanger sections line up straight. Couplings should be tightened as heat exchanger is placed, since it is more difficult to do so once the reflector is in position.

# INSTALLATION

## Heater and Baffle Installation

- Locate the burner gasket provided, bolt the burner in place on the tube flange with provided hardware. Burner must never be installed in a tilted position. The sense electrode of the burner cup should be in the 12 o'clock position (Figure 12).

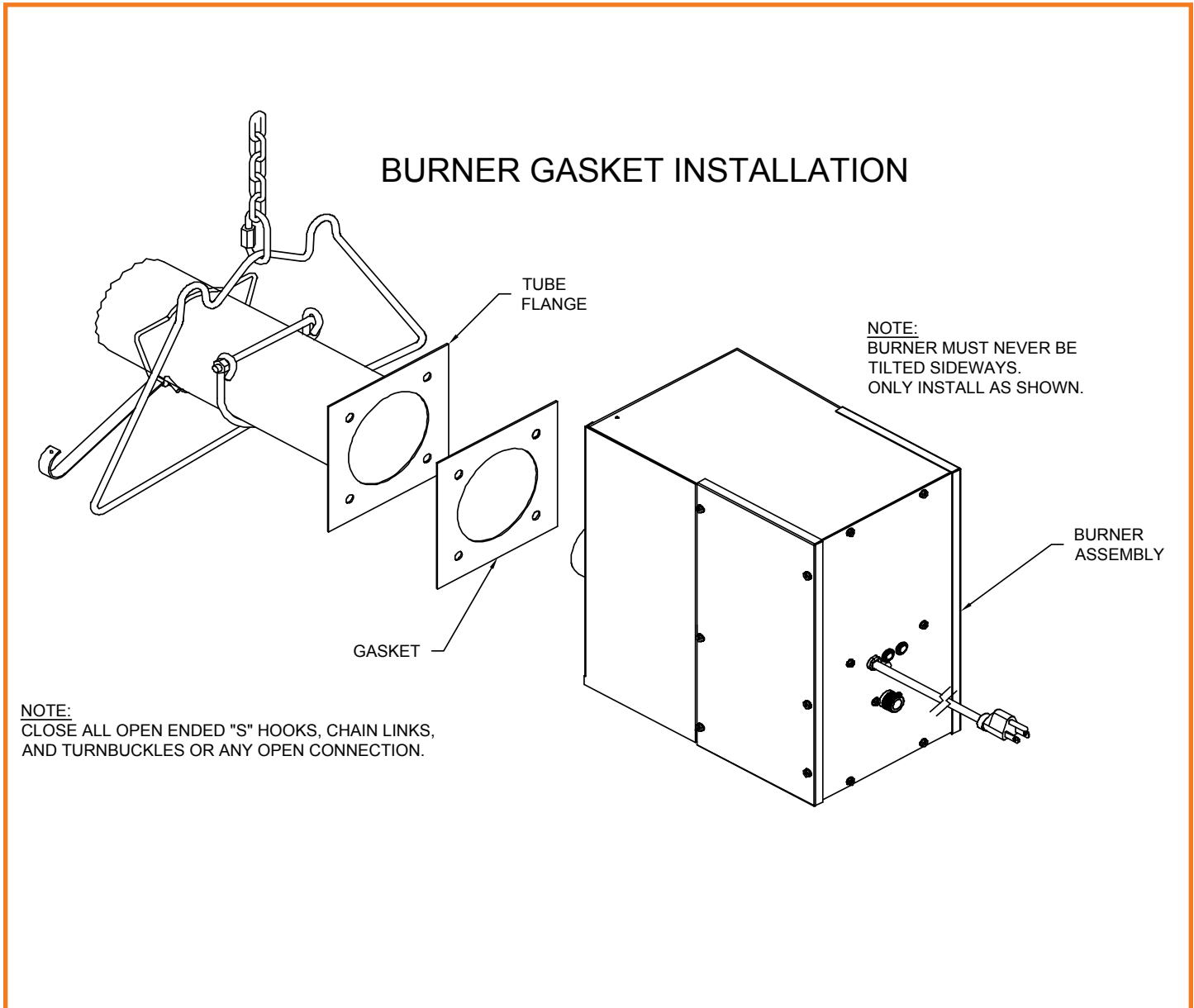

Figure 12: Burner Gasket Installation

# INSTALLATION

- If required for your heater model (refer to Table 1), install the baffle at the end of the heat exchanger. The small tab on the baffle is folded over the end of the tube and clamped in place by the vent connector and vent system, (refer to Figure 13).
  - **Note:** Baffles are always placed at the end of the last heat exchanger tube length, with the exception to the special configuration 205,000 BTU/hr with a 50' tube length, refer to for more details.
  - **Note:** Baffles are either one or two sections (each section is 6' in length). Multiple sections are simply coupled together. Where stainless and aluminized sections are supplied, always place the stainless steel section closest to the burner. The easiest installation method is to pull the baffle through the tube using a long wire.

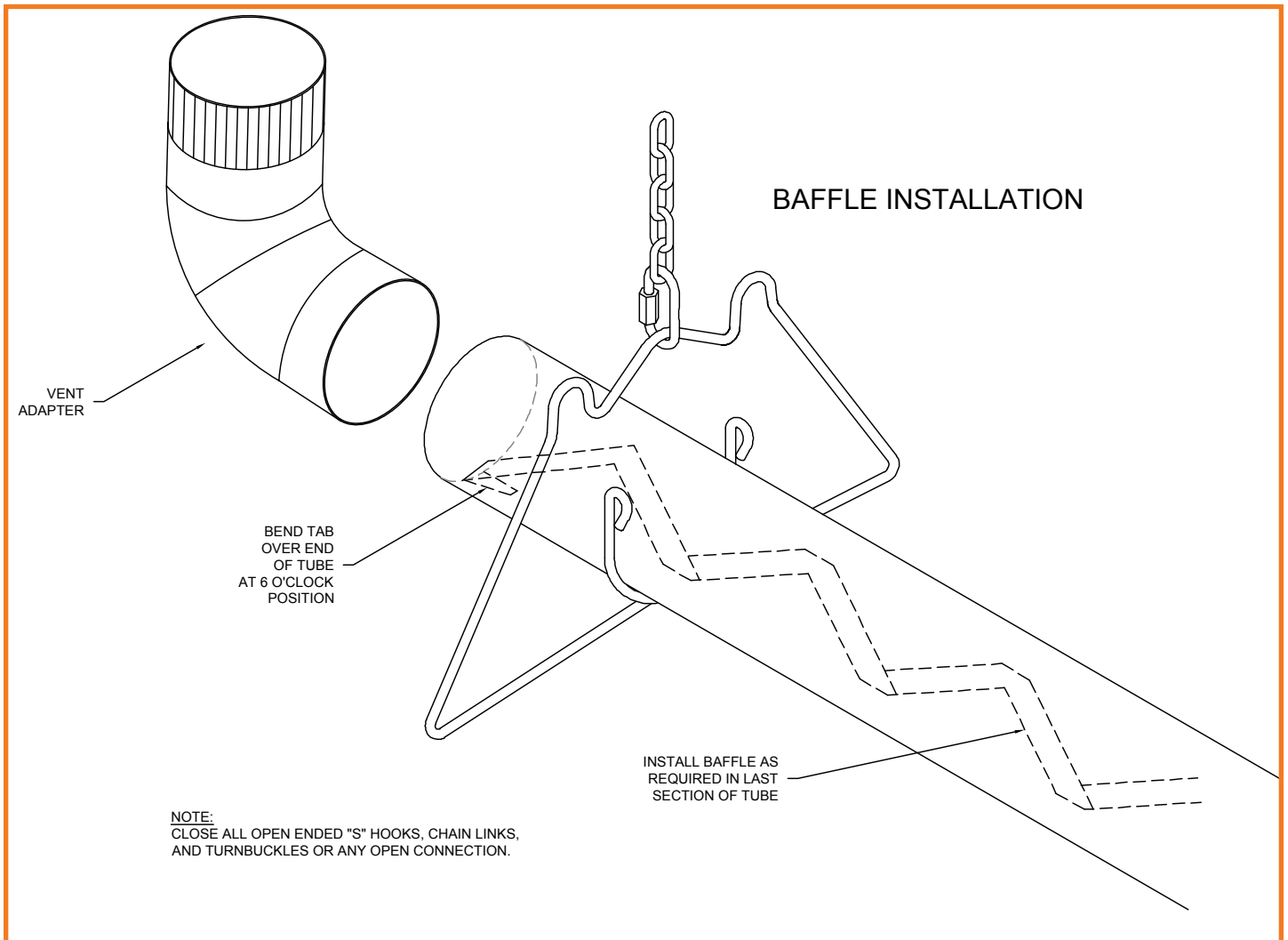

Figure 13: Baffle Installation

# INSTALLATION

## Reflector Installation

- Slide a reflector section into place within the support hanger, (Figure 14).

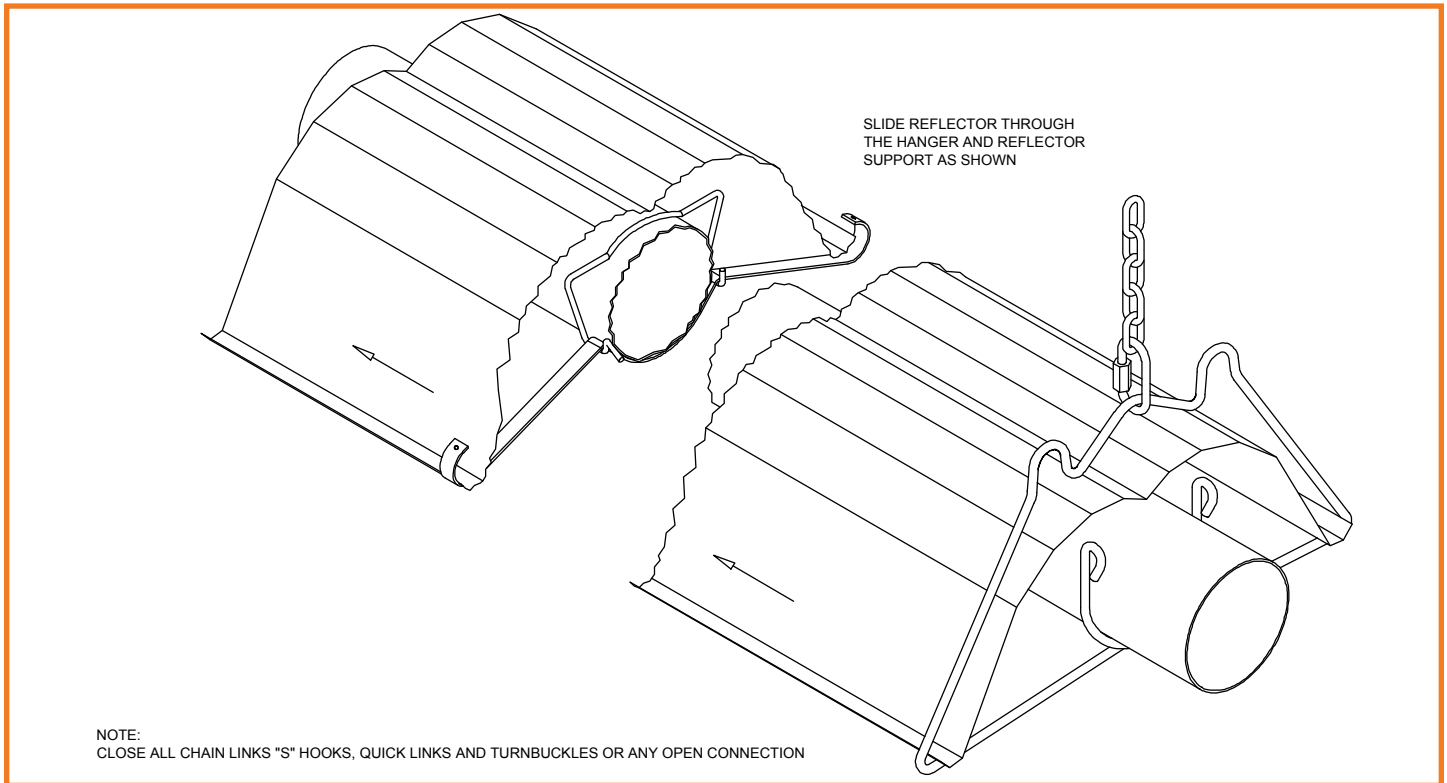

Figure 14: Reflector Installation

- Install reflector support brackets, one at each reflector overlap position, and one in the middle of each 10' reflector length. Figure 15 shows the installation of the reflector support bracket.

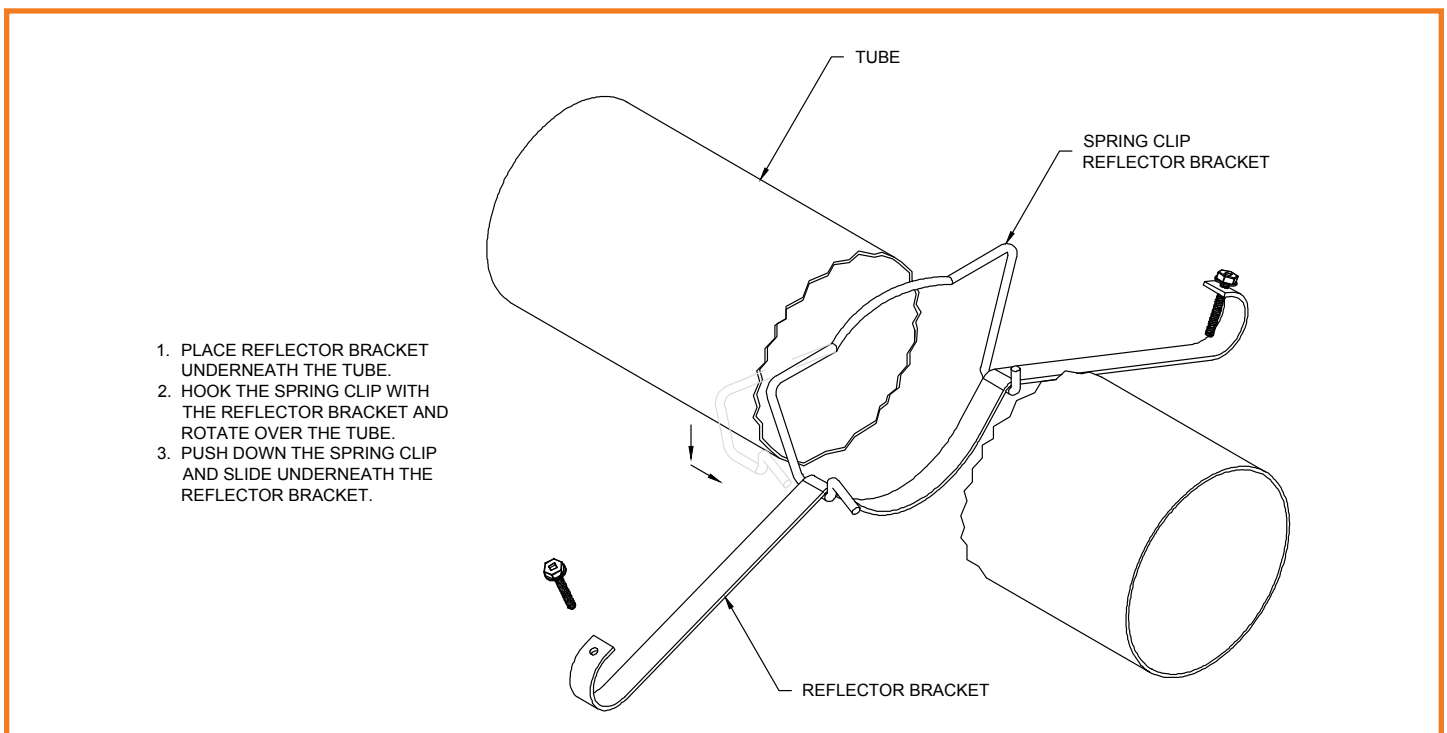

Figure 15: Reflector Support Bracket Installation

# INSTALLATION

**Note:** Reflectors should overlap adjacent reflectors 4" to 6". Be sure not to tile reflector sections; that is, reflector sections must be either above both adjacent reflector sections, or below both adjacent reflector sections. (Refer to Figure 16).

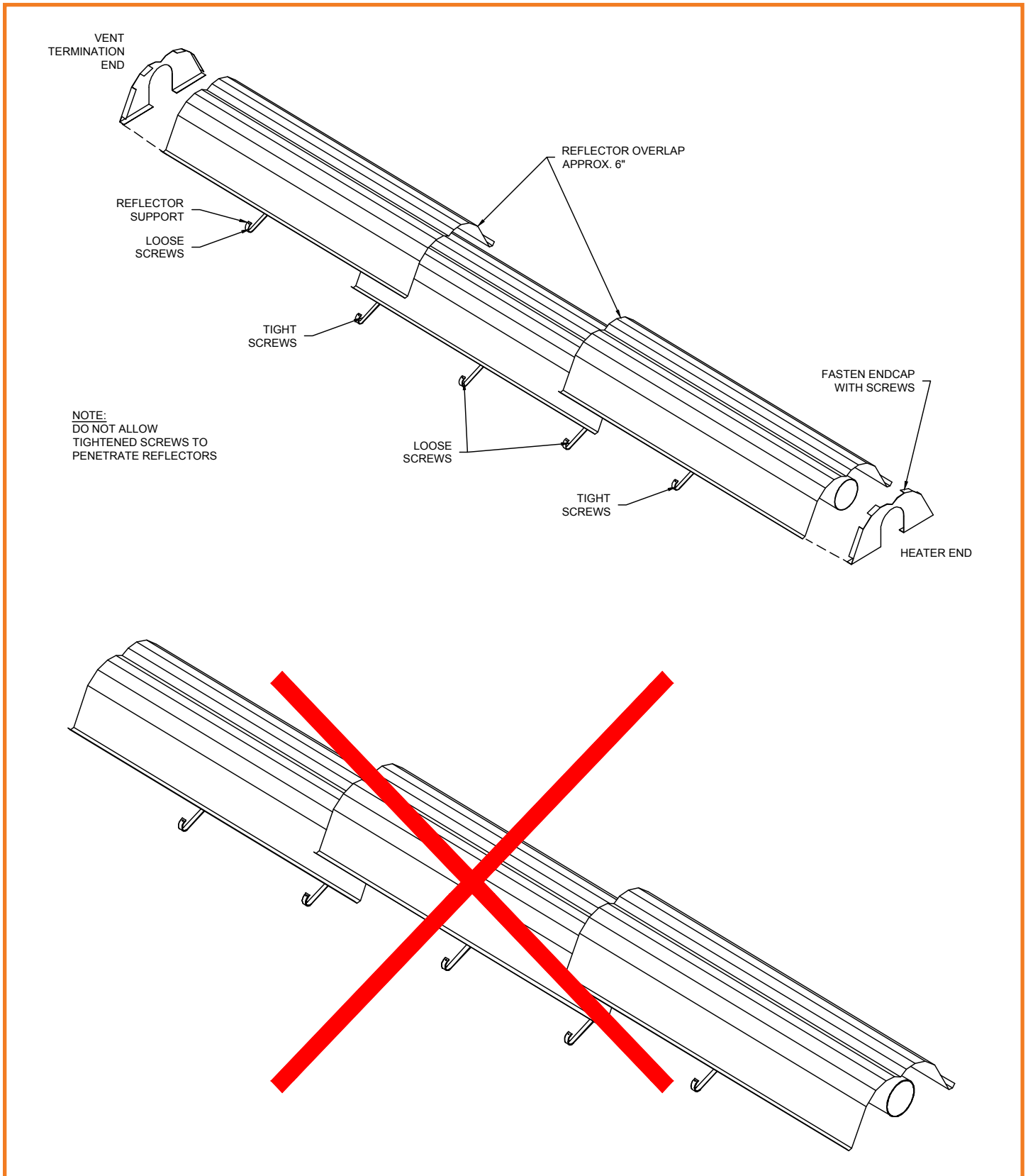

Figure 16: Reflector Support Bracket Installation

# INSTALLATION

- Secure every second reflector overlap together with a minimum of 2 - #8 x 3/8" inch long screws (not supplied), and secure reflector to the reflector bracket at this point by tightening down #8 x 1 1/4" screws supplied with reflector brackets (Figure 17). The remaining reflector overlap joints and reflector brackets are left loose to accommodate system movement.

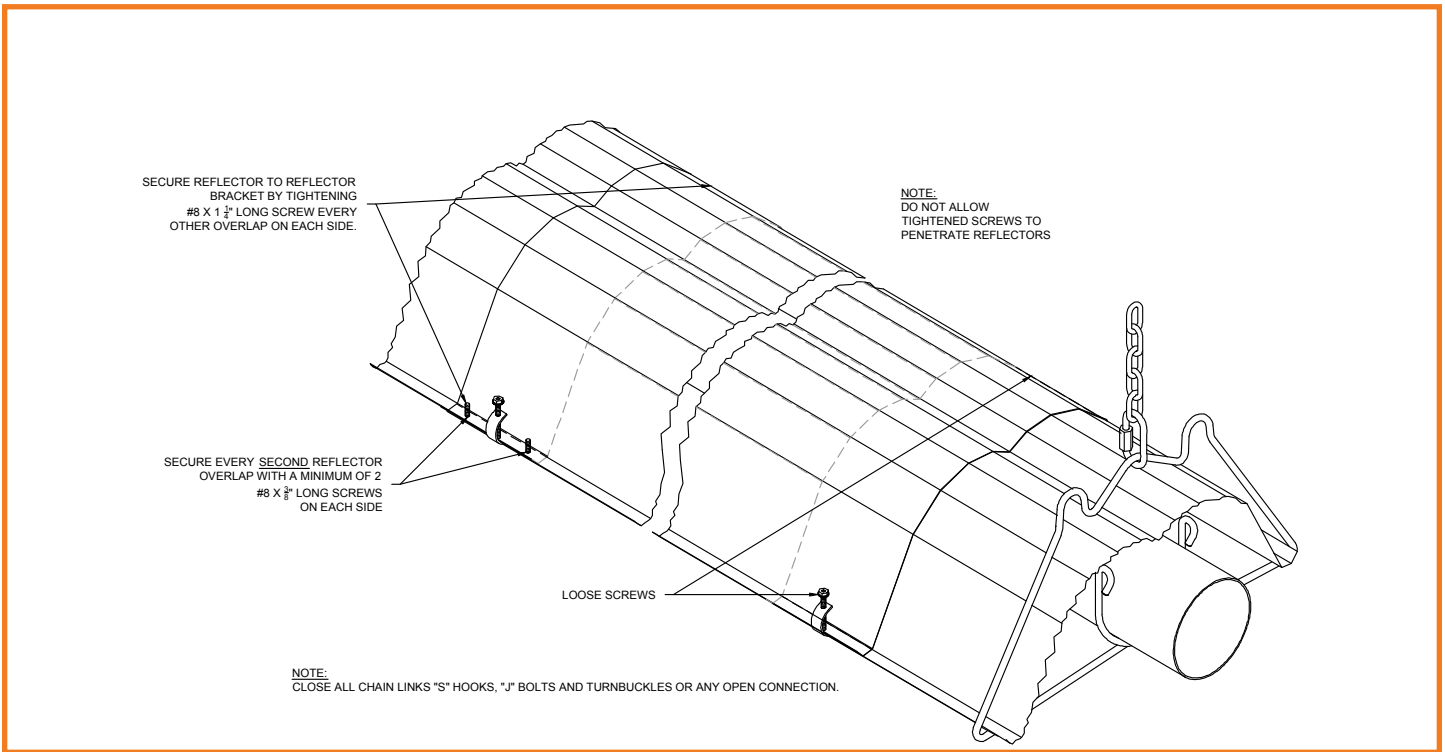

Figure 17: Reflector Supports Installation and Reflector Overlay Bracket Installation

- Install End Cap as shown in Figure 7 and Figure 18

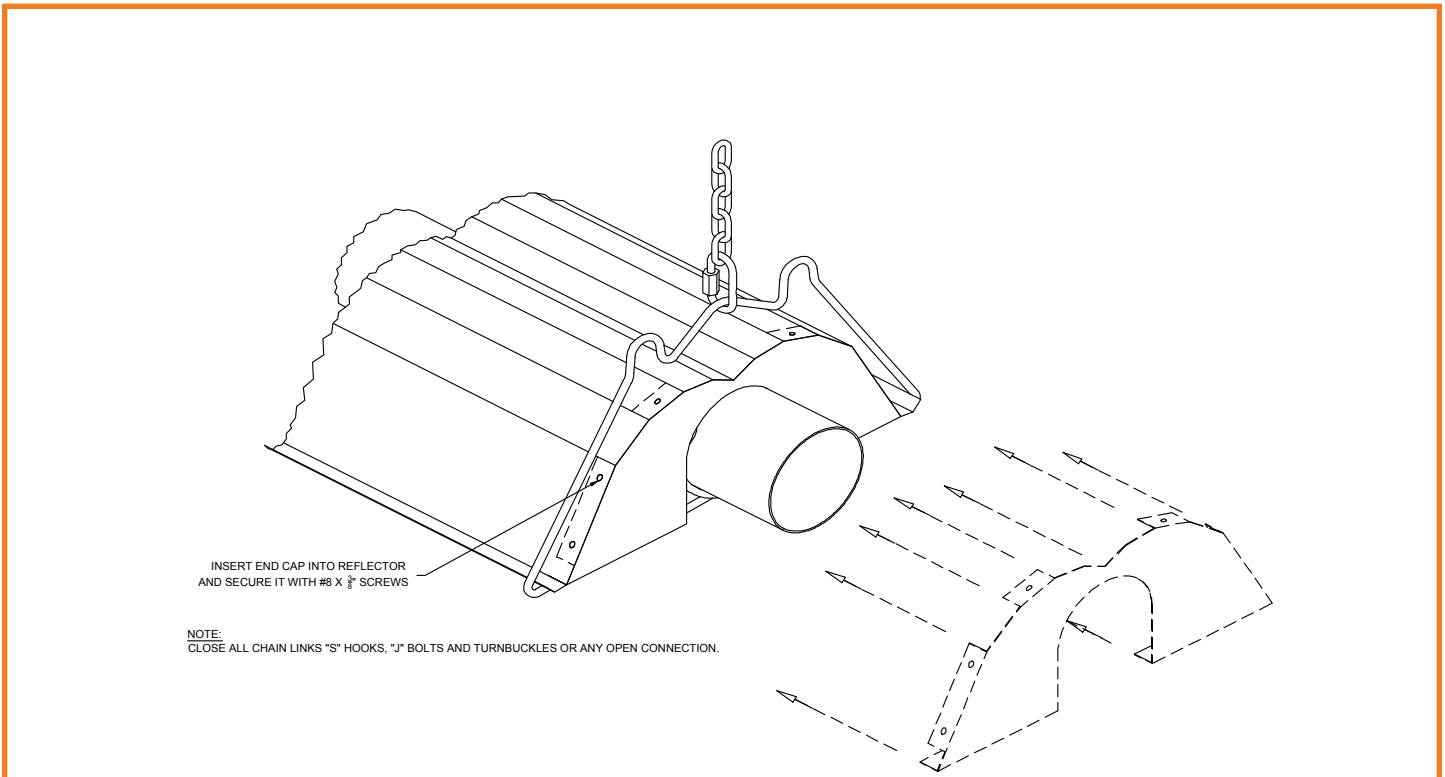

Figure 18: Reflector End Cap Installation

## Elbow and U-Bend Installation

- If required by the heater layout, install 90° elbows or U-bend tubes where indicated. Refer to Figure 19 for details.
  - **Note:** Elbows or U-bends are typically installed without reflectors. To reduce the above clearance to combustibles distance use miter reflectors (see Figure 18) and refer to *Clearance to Combustibles* information.

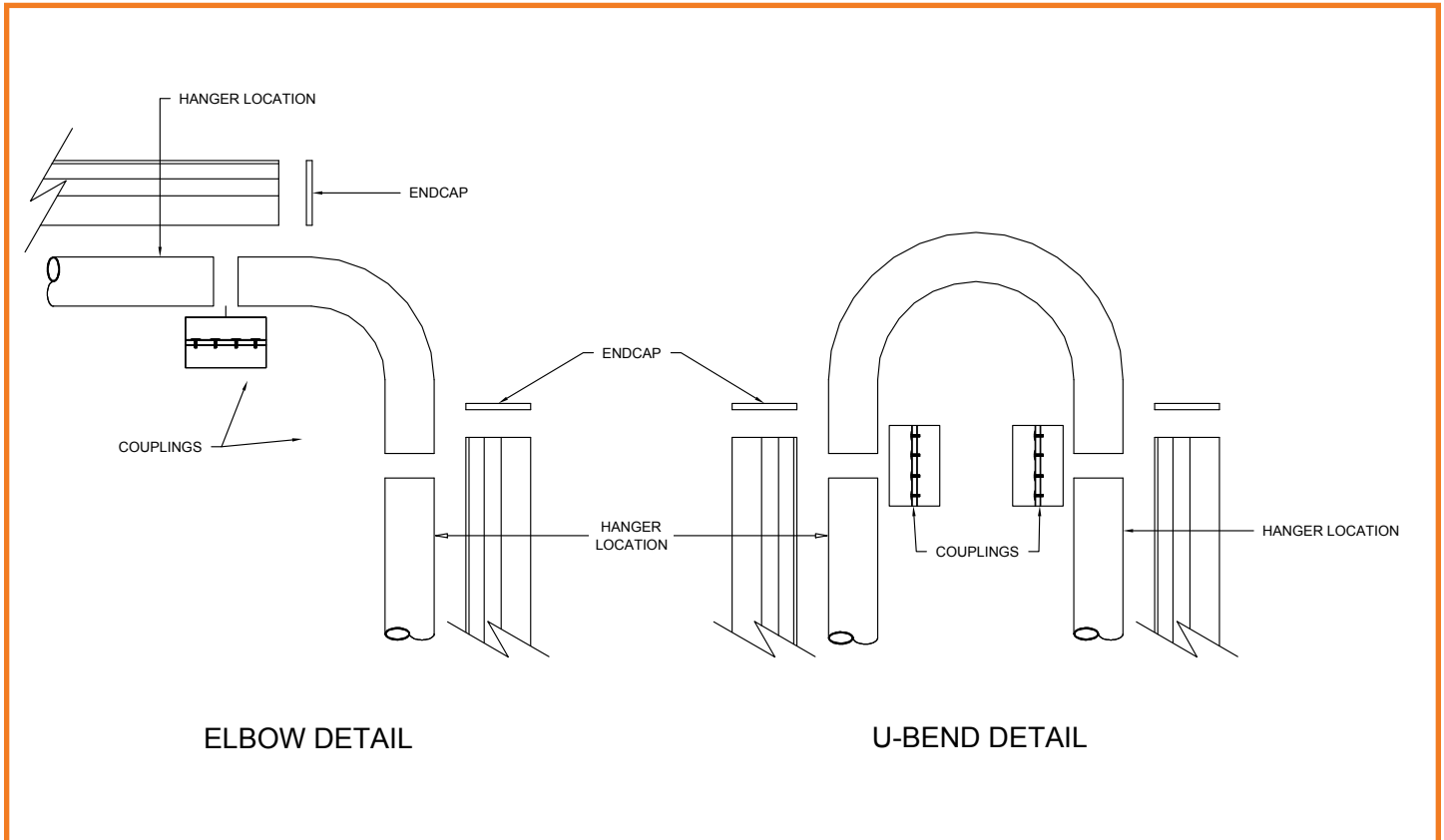

Figure 19: 90° Elbow and U-Bend Assembly Detail

- Elbows or U-bend tubes must be located not less than 10' from the burner in ES/ESH-100 and smaller models, not less than 15' from the burner in ES/ESH-125 to ES/ESH-150, and not less than 20' from the burner in ES/ESH-175 and larger models.

# INSTALLATION

## Mitered Reflector Installation

- If used, install the Mitered Reflector as shown below (Figure 20).

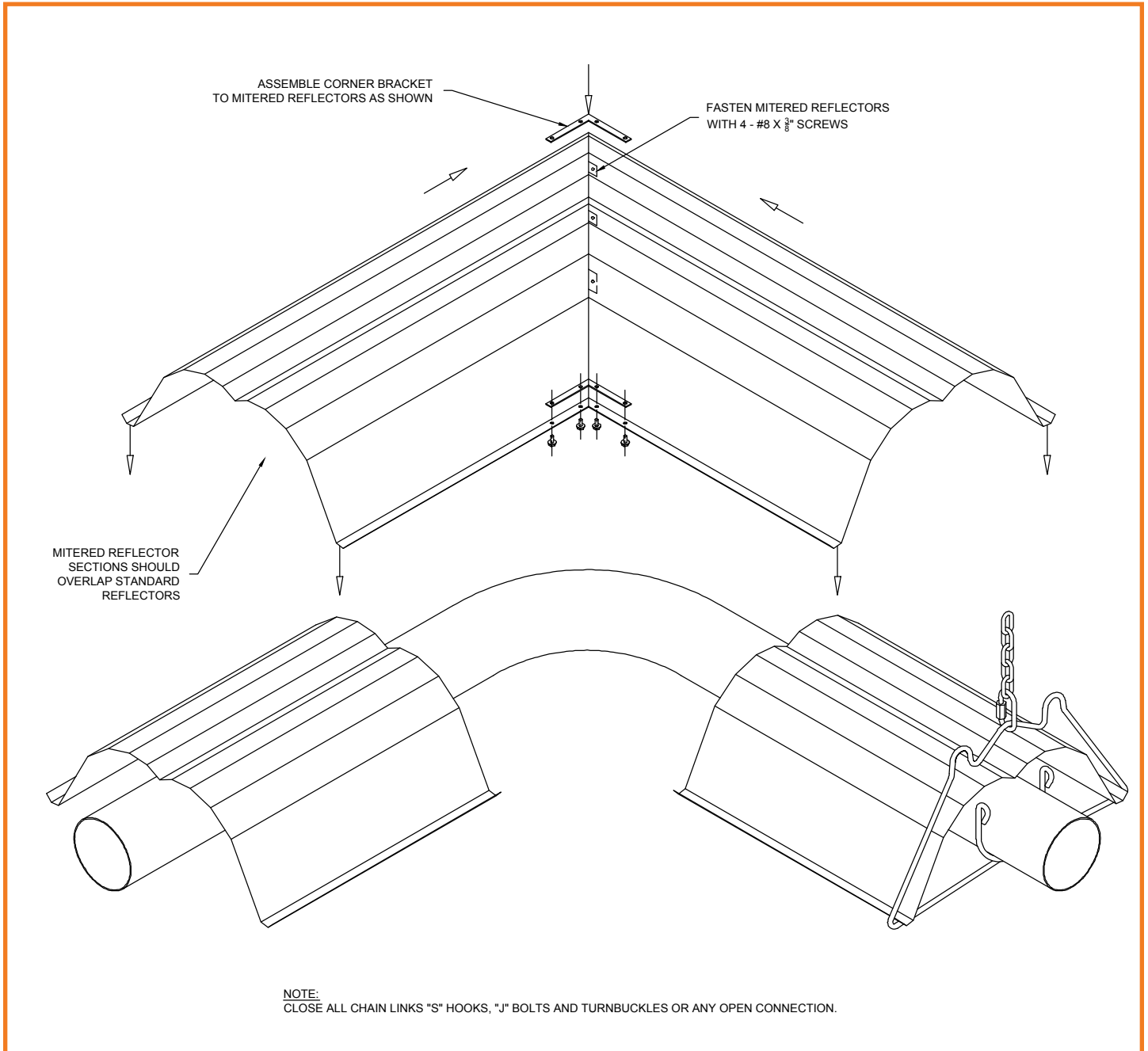

Figure 20: Mitered Reflector Installation



## Side Reflectors & Bottom Shields

- If used, install side shields (reflectors) and/or bottom shield as required. Refer to Figure 21 and Figure 22 for details.
- Side shields are 124" (315cm) long. Fasten one side shield per reflector with #8 x 3/8" screws. Use three side shield brackets per side shield. Space about 48" (122cm) apart, refer to Figure 21.

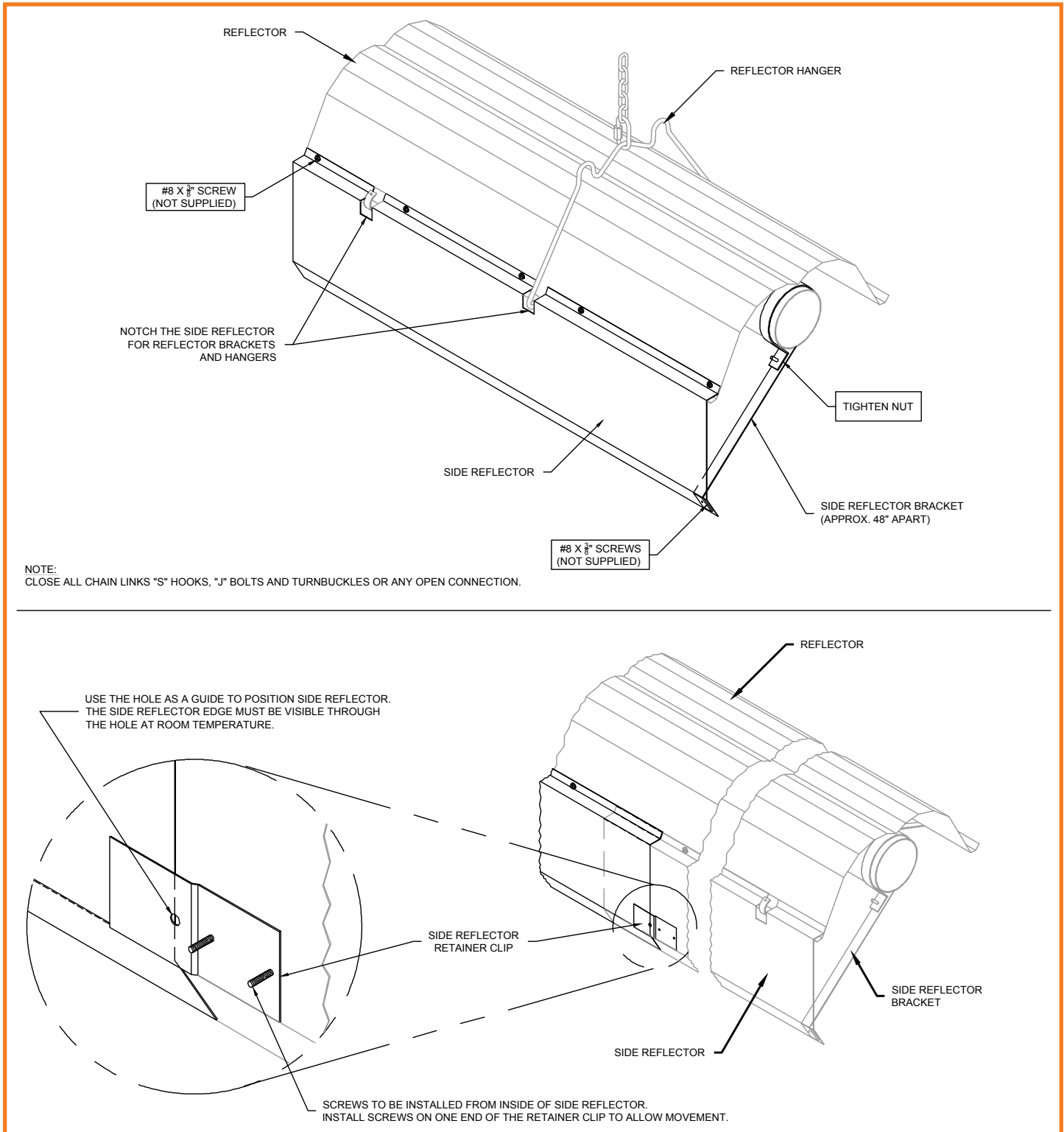

Figure 21: Side Shield Installation

# INSTALLATION

## Bottom Shield Reflector Installation

- Bottom shields need not overlap. Each 5' section is held with two support brackets (see Figure 22).

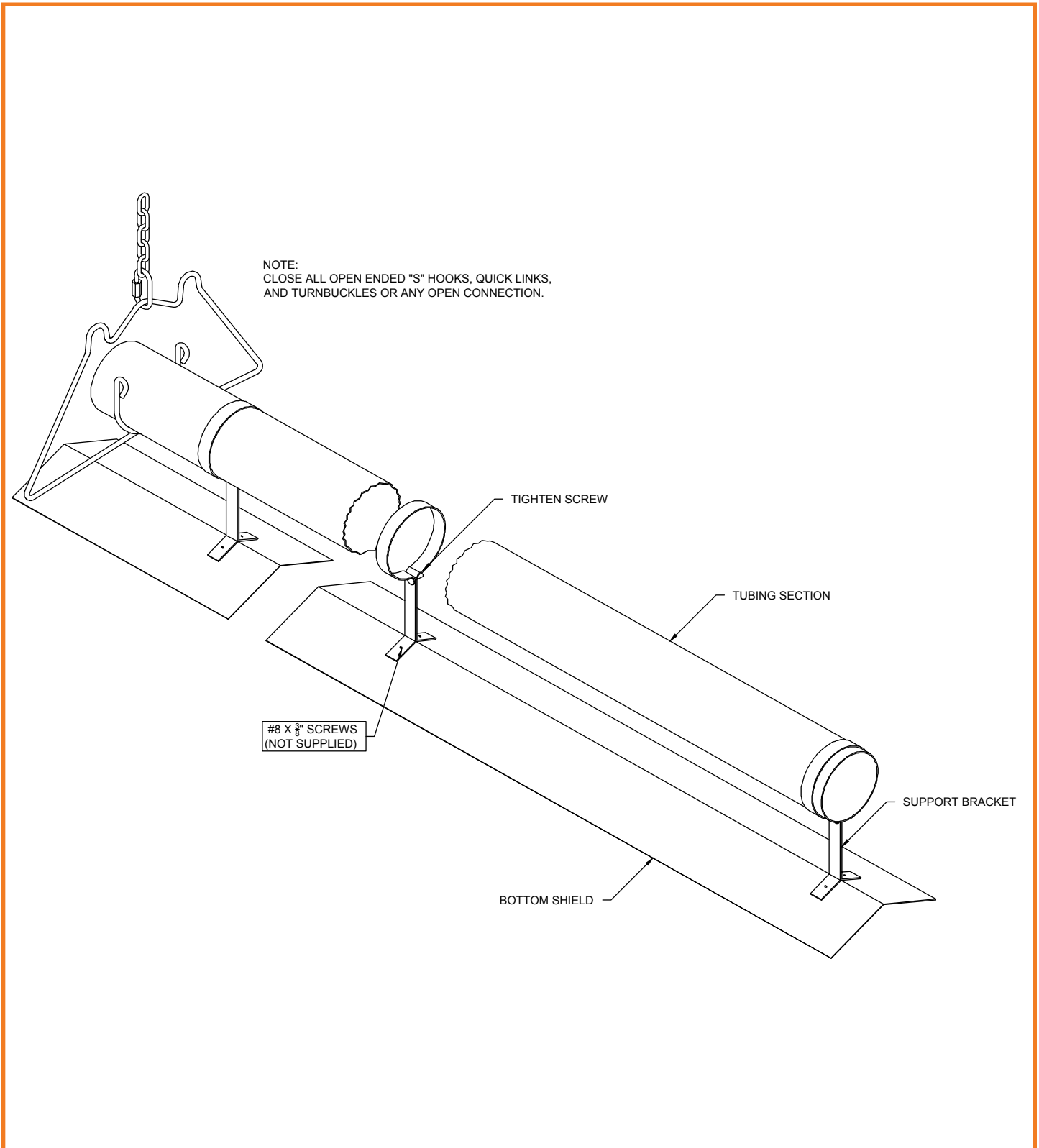

Figure 22: Bottom Shield Installation

## Decorative Grille (Optional)

ES/ESH Range heaters are approved for the addition of Decorative Grille either directly to the heater reflector or as part of a T-Bar installation where the heater is above the ceiling structure. Refer to Figure 23 and Figure 24 below for details.

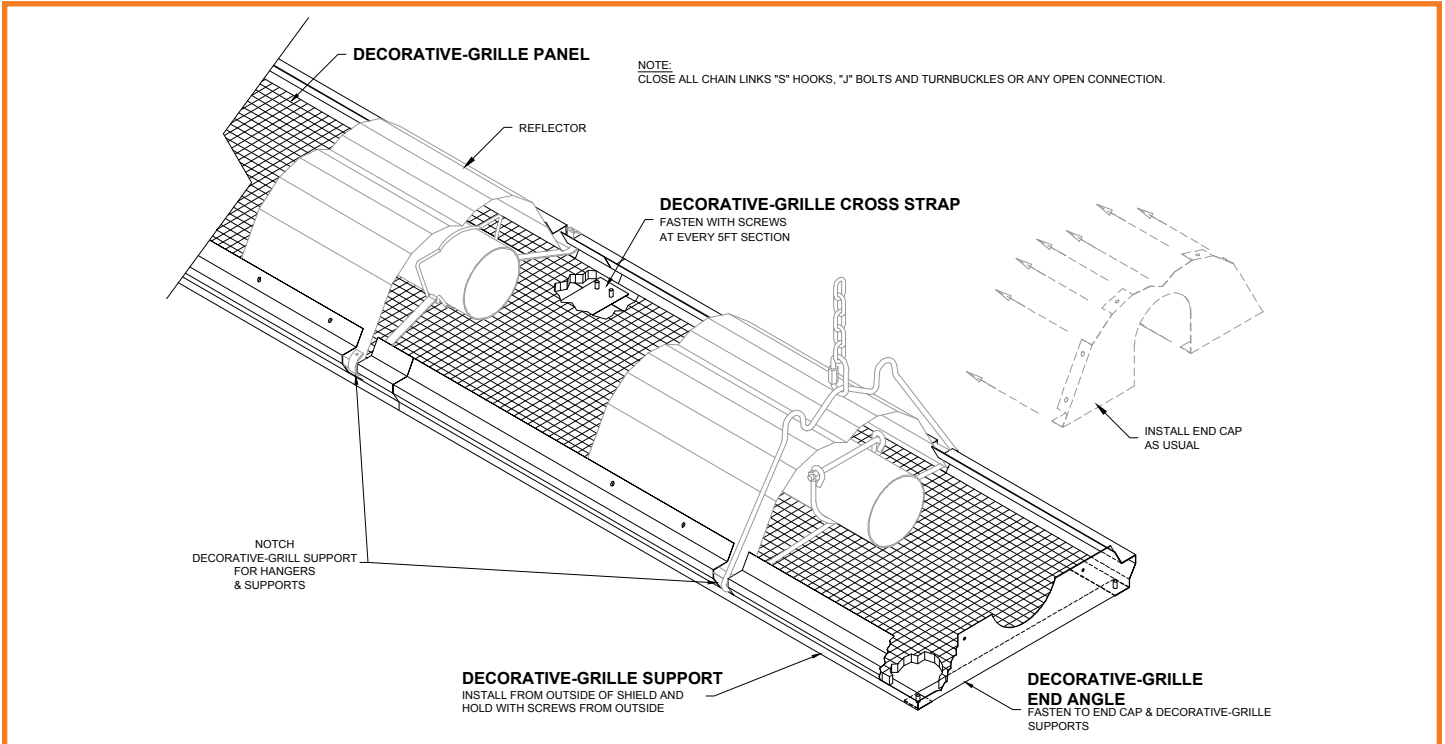

Figure 23: Decorative Grille and Heater Installation

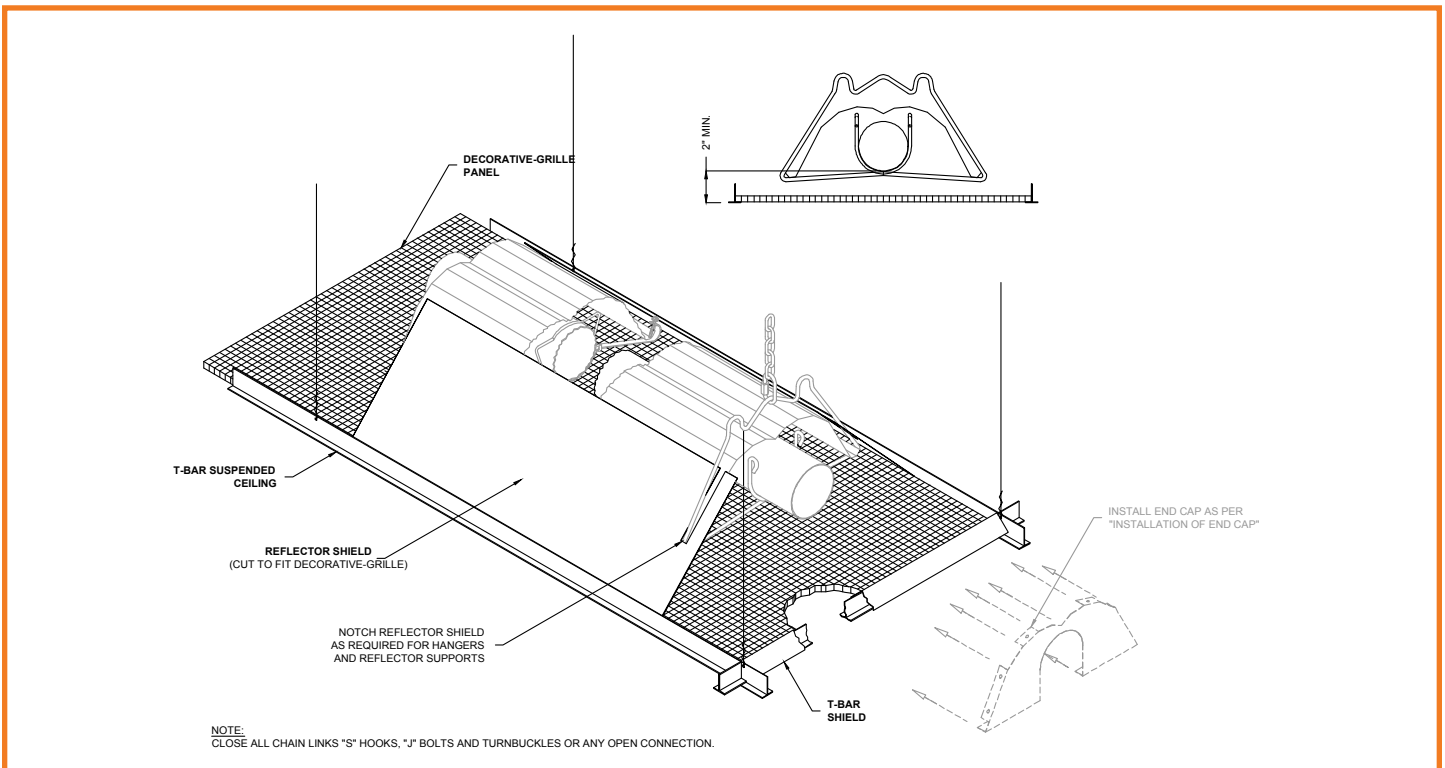

Figure 24: Decorative Grille and Heater Installation

# VENTING AND COMBUSTION AIR DUCTING

## General Requirements

- Refer to the National Fuel Gas Code, ANSI Z223.1 (NFPA 54) in the US and CSA B149.1 and B149.2 Installation Codes in Canada, as well as all local requirements for general venting guidance.
- Heaters may be installed vented or unvented.
- Heaters may be vented horizontally or vertically.
- Optional outside air supply may be directed to the heater.
- If heater is to be vented horizontally, the vent from building must:
  - Be not less than seven feet above grade when located adjacent to public walkways.
  - Terminate at least three feet above any forced air inlet located within ten feet.
  - Terminate at least four feet below, four feet horizontally from or one foot above any door, window, or gravity inlet into any building.
  - Be located at least 12" (30cm) from any opening through which vent gases could enter a building.
  - Extend beyond any combustible overhang.
  - Be installed at a height sufficient to prevent blockage by snow.
- Optional outside air supply may be directed to the heater horizontally or vertically.

### IMPORTANT

- Maximum total vent length allowed for any model heater is 30'(9m).
- Maximum total fresh air inlet duct length allowed for any model heater is 30'(9m).
- Total of vent length plus outside air supply duct length cannot exceed 50'(15m). for any heater with minimum heat exchanger length.
- If condensation in the vent pipe or outside air supply duct is a problem, shorten or adequately insulate the section.
- Install a minimum 18 inch (30 cm) straight length of duct for air intake or vent before any Tee or elbow.
- Do not install any elbow or 45° fitting to bring vent lower than the horizontal tube system

**Note: The above stated requirements assume a maximum of 2 elbows in the total combination of vent and air supply duct. Subtract 5' of allowable length for each elbow if 3 or more elbows are used.**

## Un-Vented Operation

- Requirements for combustion air supply and dilution air vary by jurisdiction, building type and specific installation details. See local codes for guidance. In general, fresh air ventilation must be provided to the building space at (3 cfm per 1000 BTU/Hr in Canada). In The USA verify applicable codes.
- Optional outside air supply is not recommended for unvented heaters due to possible pressure imbalances in the building space.
- Ensure that minimum combustible clearances are maintained for unvented heaters. Refer to Table 2, for required clearance dimensions.

# VENTING AND COMBUSTION AIR DUCTING

## Vented Operation

In all cases, be sure vent pipes and outside air supply ducts are sealed with approved sealant, such as high temperature RTV silicone. Double wall venting (B vent) may not require sealant.

## Horizontal Venting

- When venting through combustible walls, use approved vent terminal Tjernlund VH1-4, or supplied deflector vent terminal with an approved insulating thimble.
- When venting through non-combustible walls, use supplied deflector vent terminal. Recommended extension of the terminal past the outside wall surface is 18" inches minimum.

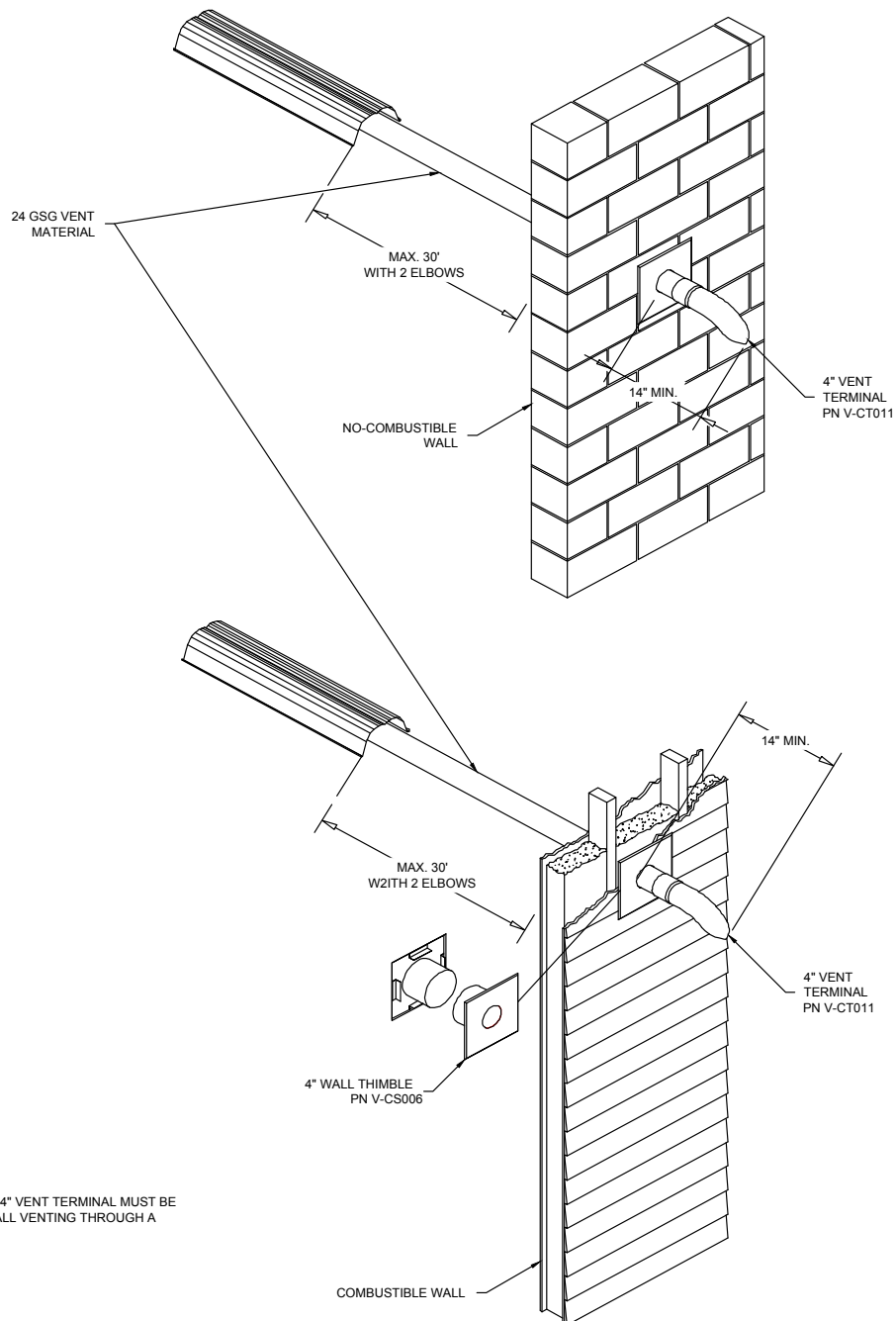

Figure 25: Horizontal Venting

# VENTING AND COMBUSTION AIR DUCTING

## Common Horizontal Venting

- All heaters connected to a common horizontal vent must operate at the same time. Connect the electrical circuit to the same thermostat to ensure simultaneous operation.
- Fresh air supply CANNOT supply other burner systems.
- Refer to Figure 26 for detailed common horizontal venting guidelines.

### COMMON VENTING FOR HEATERS WITH A COMBINED TOTAL INPUT OF 250,000 BTU OR GREATER

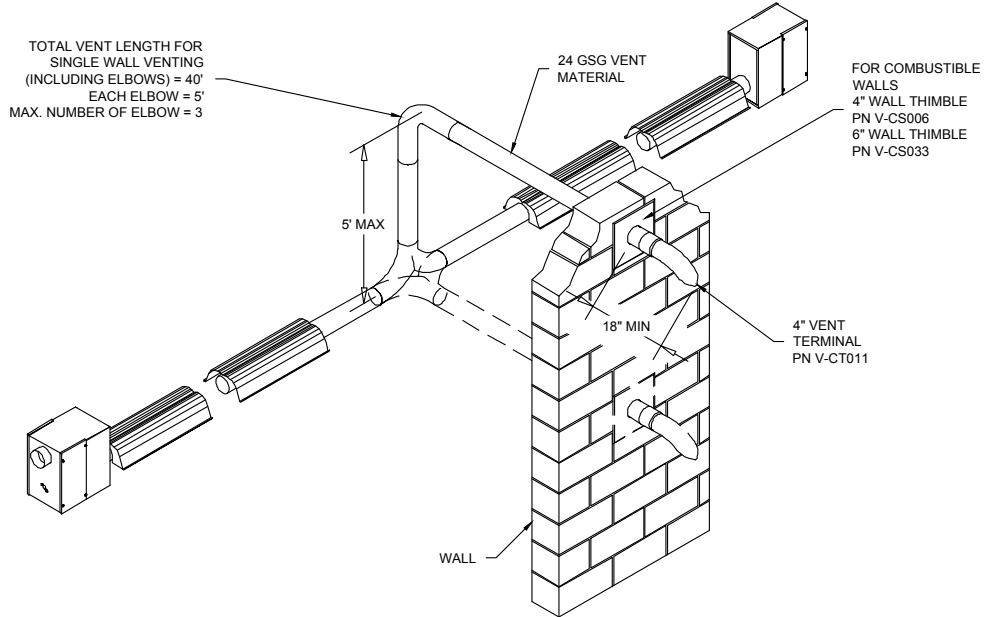

### COMMON VENTING FOR HEATERS WITH A COMBINED TOTAL INPUT OF UP TO 250,000 BTU

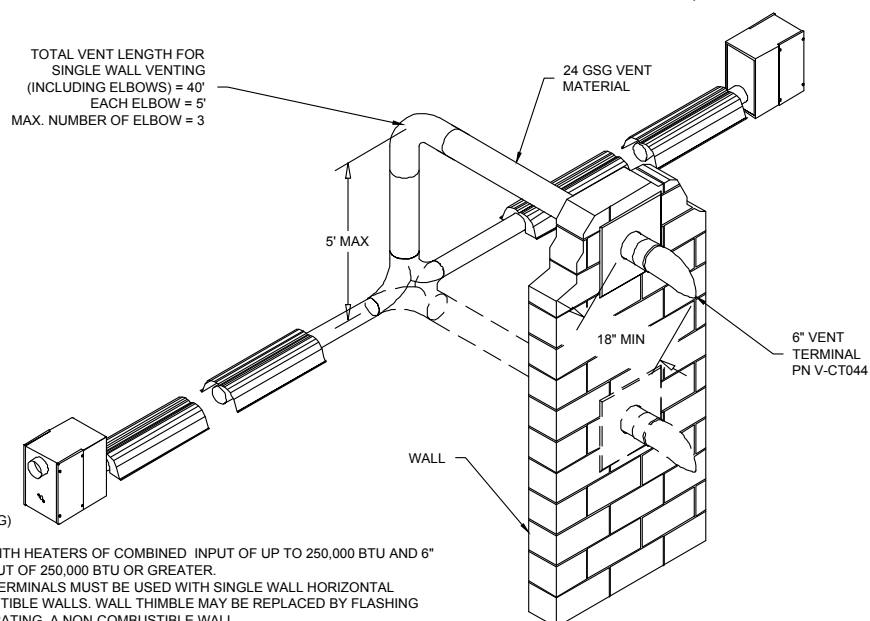

Figure 26: Common Horizontal Venting

# VENTING AND COMBUSTION AIR DUCTING

## Vertical Venting

- Minimum vent pipe size is 4"(10cm) for an individual heater. Additional vent pipe sizes as required to accommodate multiple heaters venting through a common roof vent are defined in the appropriate gas installation code. (Refer to common venting section below).
- Use of an approved thimble to pass through combustible roof materials is required.
- Use of an approved vent cap is required.
- Check local codes for vertical vent size

## Common Vertical Venting

- Common vent sizing information is defined in the appropriate gas installation code (Refer to ANSI Z223.1 and CSA B149.1 and B149.2 for sizes and installation information).
- For vertical venting refer to ANSI Z223.1 and CSA B149.1 and B149.2
- Connection locations to the common vent should be offset to avoid pressure interferences between heaters, refer to ANSI Z223.1 and CSA B149.1 and B149.2
- Use of approved thimble to pass through combustible roof material is required. Additionally, B type vent materials are required for stacks above the roof line.
- Use of approved vent cap is required.
- All heaters to a common vent must operate at the same time. Connect the electrical circuit to the same thermostat to ensure simultaneous operation.

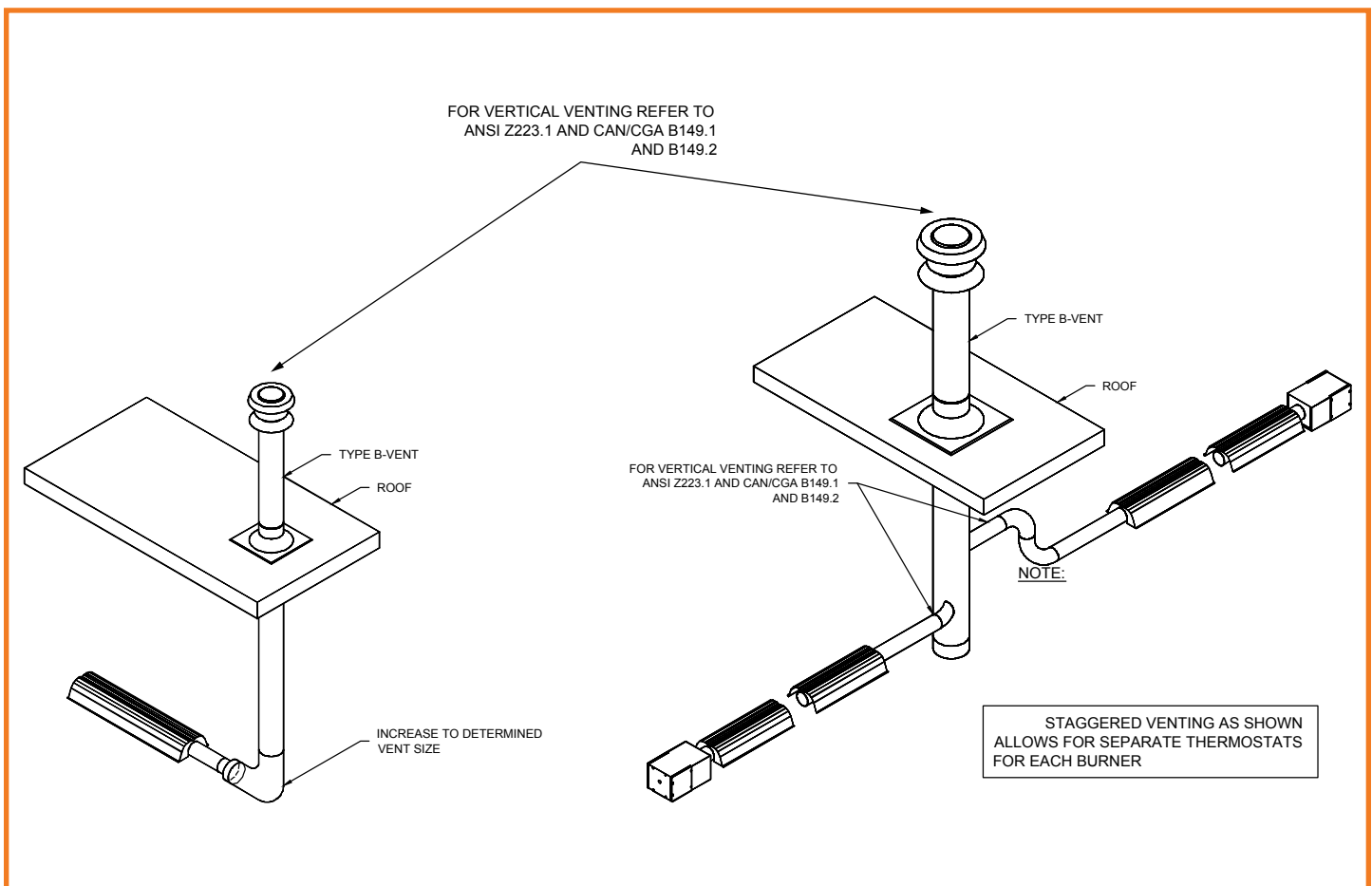

Figure 27: Common Vertical Venting

# VENTING AND COMBUSTION AIR DUCTING

## Combustion Air Supply (Optional)

- An outside combustion air supply is strongly recommended if the building space encloses a negative pressure due to exhaust etc. or if the building contains materials which would expose the heater to halogenated hydrocarbon atmospheres.
- The outside air terminal must be of an approved type, and should be located at an elevation equal to or below the vent terminal elevation to prevent back-venting of flue gases into the burner compartment.
- Install single wall pipe or PVC pipe and fittings with a 12-inch linear section of flexible duct to allow movement of the heater. Do not use flexible duct throughout the entire length of fresh air duct. This may cause nuisance air switch tripping.

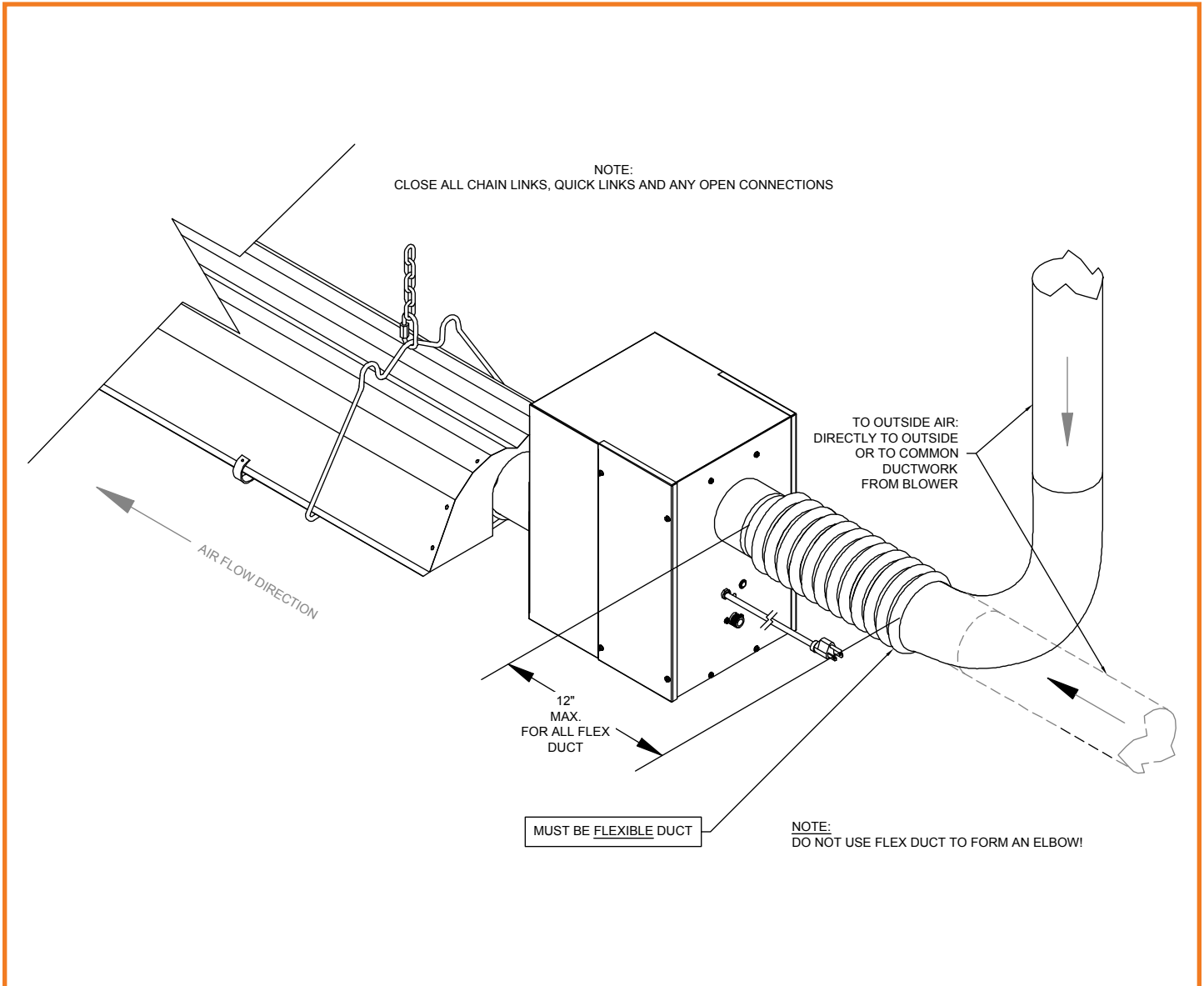

Figure 28: Installation of Outside Air as Supply for Combustion



# VENTING AND COMBUSTION AIR DUCTING

## Outdoor Installation (ESH MODELS ONLY)

When a heater is to be mounted outdoors it must be installed in such a way that wind will have minimum effect on its movement. This consideration is intended to eliminate undue stress on the gas flex connector.

In all cases a fresh air hood must be used in conjunction with a vent terminal of the approved type, and all connections must be sealed with a high temperature sealant that can withstand 400°F.

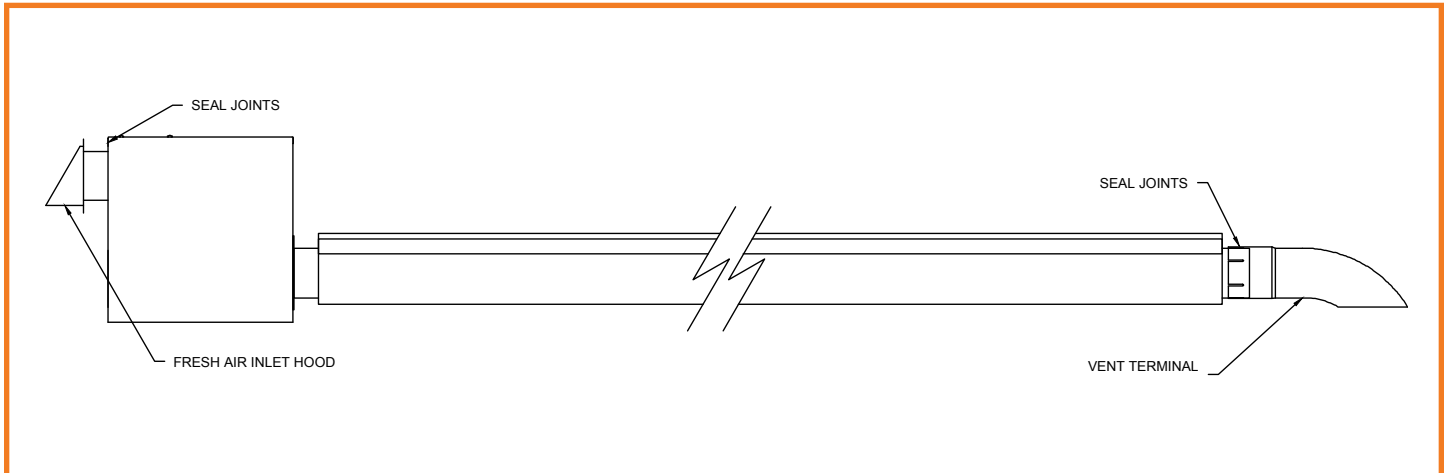

Figure 29: Outdoor Installation for ESH models only

**Note: that this heater is a sealed construction. If any services or repair is conducted in the future, gasket materials should be inspected and replaced if found to be deteriorated.**

# GAS PIPING

## General Requirements

- The gas meter and service must be sufficiently large to supply gas to the connected building gas load including the heating equipment and any other gas fired equipment. Additionally, the gas distribution piping must be designed according to local and national ordinances. Generally (low pressure) systems designed with a maximum ½ in W.C. total pressure drop meet this requirement
- Gas supply pipe sizing must be in accordance with the National Fuel Gas Code, ANSI Z223.1 (NFPA 54) in the US and CSA B149.1 and B149.2 Installation Codes in Canada.
- Before connecting burners to the gas supply system, verify that high pressure testing of the system has been completed. Failure to do so may expose the burner components to damaging high pressure, requiring replacement of key components.

Flexible gas connectors of approved type must be installed as shown in Figure 30, in one plane, and without sharp bends, kinks or twists. A smooth loop of approximately 12 in (30 cm) in diameter is best. Failure to install the gas connection in the approved manner will result in a hazardous and potentially deadly situation due to the movement of the heat exchanger and burner in the normal course of operation.

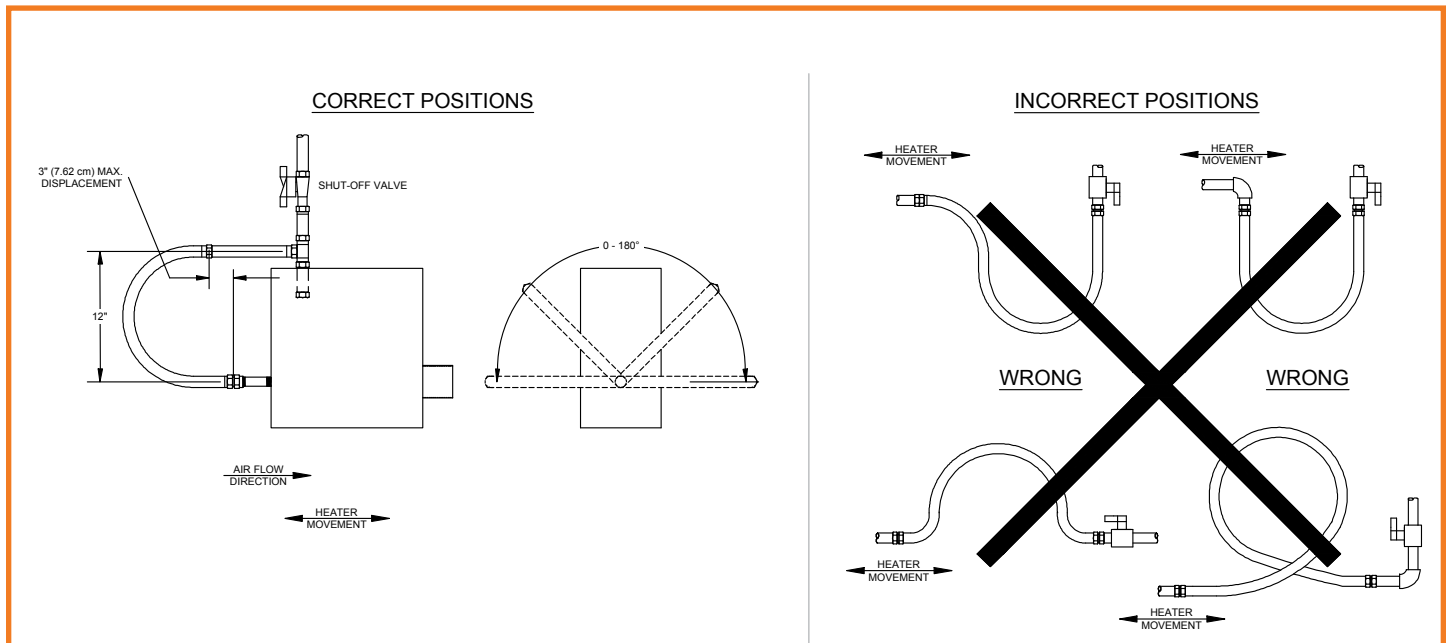

Figure 30: Flexible Gas Connections

# ELECTRICAL WIRING

## General Requirements

Heaters are normally controlled by line voltage (120V) or low voltage (24V) thermostats. They are both wired directly. In all cases, heaters must be grounded in accordance with the National Electric Code, ANSI/NFPA 70 in the US, and the Canadian Electric Code, CSA C22.1 in Canada, and must comply with all local requirements. Heaters may also be controlled with a manual line switch or timer switch in place of the thermostat. Refer to Figure 30 & 31 for guidance on electrical wiring of heaters.

If any of the original wire as supplied with the heater must be replaced, it must be replaced with wiring having a rating of at least 105°C temperature service and 600 volts capability.





## Starting Sequence of Operation

- Turn the thermostat up. When the thermostat calls for heat, both blower motors will energize
- After the blower is running, the air-proving switch closes and activates the ignition module.
- The ignition module, after a pre-purge period of approximately 30 seconds, energizes the igniter. Then, the gas valve is energized for this ignition trial period of 15 seconds.
  - If a flame is detected, the ignition sensing rod “reads” a rectification signal and the gas valve remains open. The sparking stops when the flame signal is established.
  - If no flame is detected, the gas valve closes and a 30 second inter-purge period begins.
  - After the inter-purge, the module repeats the trial for an ignition period.
- If a flame is still not established, a third and final inter-purge followed by a final ignition trial cycle begins. After three trials, the module will lockout for a period of approximately 1 hour or until reset. (Reset is accomplished by removing power from the module for at least 5 seconds.) After this 1 hour period, the module re-attempts the full ignition sequence.

When using a 24V thermostat, and the heat requirement has been met and the thermostat opens, the burner shuts off but the blowers will continue to run for approximately 30 seconds. This is referred to as a post purge. This allows the products of combustion to be removed from the heat exchanger to avoid nuisance condensation and increase heat exchanger life.

When using a line voltage thermostat and the heat requirement has been met and the thermostat opens, the burner and fan shut off with no post purge.

## Maintenance

For best performance, certain minimal maintenance procedures should be performed before each heating season:

- Installation environment and best practices should be considered in determining frequency.
- Before performing any services or maintenance, shut off gas and electrical supply to heater.
- Check condition of heat exchanger forced air blower. Dirt and dust may be blown or vacuumed from the blower.
- Check condition of heat exchanger. Dirt and dust may be blown or vacuumed from the heat exchanger core / box.
- Check condition of burner box blower by removing the flex duct. Dirt and dust may be blown or vacuumed from the blower.
- Check condition of burner. Remove any foreign objects or debris from inside the burner box or burner cup.
- Inspect the igniter. Replace igniter if there is excessive wear or erosion, breakage or other defects.
- Be sure the burner observation window is clean and free of cracks or holes. Clean or replace as necessary.
- Check the flue pipe for soot or dirt and reattach to the heater after cleaning as necessary.
- The reflector sections may be cleaned by wiping with a damp cloth.
- A service agency qualified to adjust and repair infrared heaters should be engaged for service other than routine maintenance.
- Be sure vent terminal and fresh air inlet are free from obstructions. If either pipe is restricted, the safety air switch will not operate properly, and the heater could fail to operate.
- Check the inside of the radiant tubes visually with a flashlight. If carbon or scale are present, scrape or otherwise remove deposits (a wire brush works well)

# INSTALLATION CHECKLIST

**Note: Complete checklist before lighting the heater. Correct any conditions that do not meet these instructions.**

- Did you install the first hanger no more than 8 inches from the burner and tighten with the J-bolt? (J-bolt only required for the first hanger).
- Is the weld seam facing down?
- Is the tube system leveled?
- Did you mount the tube couplings with the band clamp lock bolts oriented at the 10 o' clock or 2 o' clock position?
- Did you robustly tighten the band clamps on the tube couplings? Recommended method is to alternate back and forth between two band clamps to ensure even torque on tube couplings.
- Did you alternately overlap reflectors up and down as shown in the manual? Minimum overlap is 4 inches.
- Did you tighten up all "S" hooks or Quick links?
- Did you install all of the reflector support brackets supplied as shown in the manual? E.g. One at each overlap, and one in the middle of each reflector.
- Did you place the turbulator/flue baffle in the flue end of the heater as mentioned in the manual? Keep baffle tube 6 o' clock and bend as mentioned in the manual.
- Did you install end caps?
- Did you observe clearance to combustibles for this model according to the manual? This can also be found on the burner box.
- Is venting in accordance with the National Fuel Gas Code, ANSI Z223.1 (NFPA 54) in the US and CSA B149.1 and B149.2 Installation Codes in Canada?
- Did you install flex duct according to the installation manual if outside combustion air is used?
- Did you install the gas flex connector as shown in the manual? The legally required method is to ensure it is arranged as shown to allow for proper expansion and contraction.
- Did you check gas pressure at inlet of gas valve? Your heater will not perform properly if the pressure is not correct. Please check manual for reference

**After all actions on the checklist are checked / completed - proceed with start up.**

## Blower Motor Fails To Run

- Is the thermostat calling for heat? Is there 115V at the burner receptacle?
- Check blower side door for seal. Repair if necessary
- Check blower for obstructions. Replace blower if necessary.

## No Gas Supply

- Check to see if manual supply valve to heater is ON (Open). No manifold pressure indicates valve is closed. Gas pressure downstream of gas control can be measured by connecting a manometer to pressure tap on control. If the valve is closed, neither the gas valve knob on heater gas control is ON.
- Supply gas pressure can be checked at 1/8 in NPT pressure tap in gas supply system.
- Is combination gas control gas valve or the ignition module is faulty.

## Burner Does Not Light

- Is spark visible through site glass during ignition trial? If no, further electrical checks by a qualified service person are required.
- Check to see if gas lines were properly purged of air.
- Check inlet and outlet gas pressure during ignition period.
- Check for proper orifice and air plate.

## Burner Does Not Stay Lit

- Check ground wire continuity.
- Check insulation on the igniter leads.
- Measure flame signal current; it should be between 2 to 6 micro amps DC. Minimum 0.8 micro amps
- Clean flame rod if necessary.
- Replace module if necessary.

## Module Codes

### Module Codes (CNE/FENWAL)

- ◇ **1 FLASH** - Air Flow Issue
- ◇◇ **2 FLASHES** - Flame Sensor Issue
- ◇◇◇ **3 FLASHES** - Ignition Lockout (after 3 failed attempts)

### Potted (Channel Products)

- ◇ **1 FLASH** - Air Flow Issue
- ◇◇ **2 FLASHES** - Flame Sensor Issue
- ◇◇◇ **3 FLASHES** - Ignition Lockout (after 3 failed attempts)
- ◇◇◇◇ **4 Flashes** - Gas Valve Not Connected

# TROUBLESHOOTING

## Troubleshooting Chart

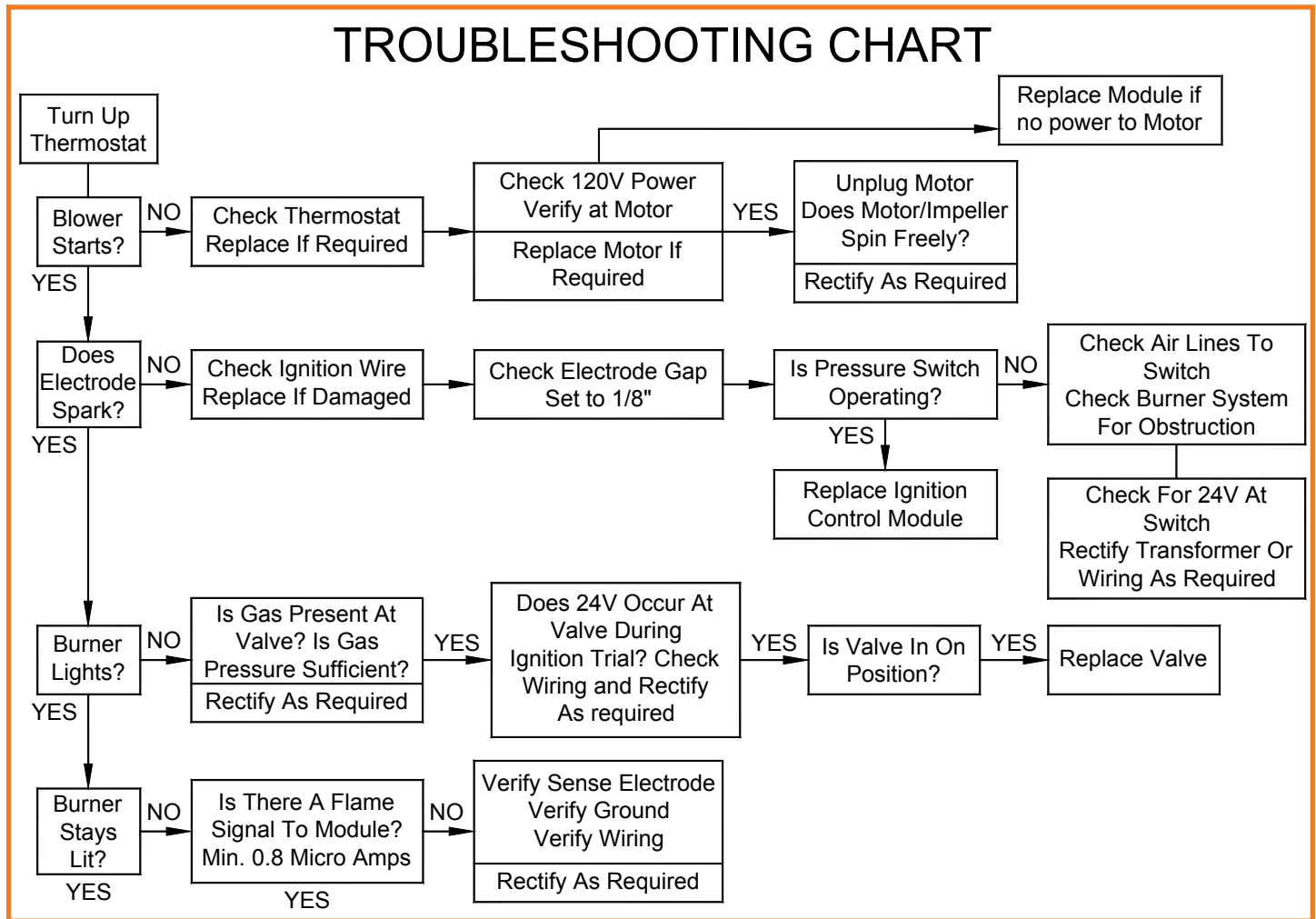

***If problems persist contact your Advanced Radiant Systems Representative.***





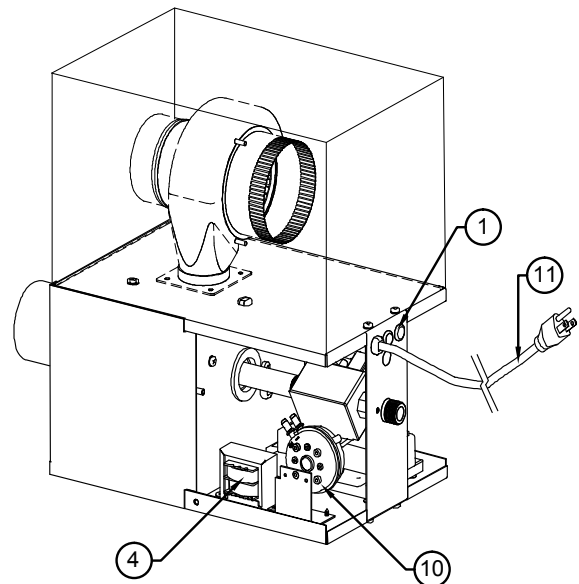
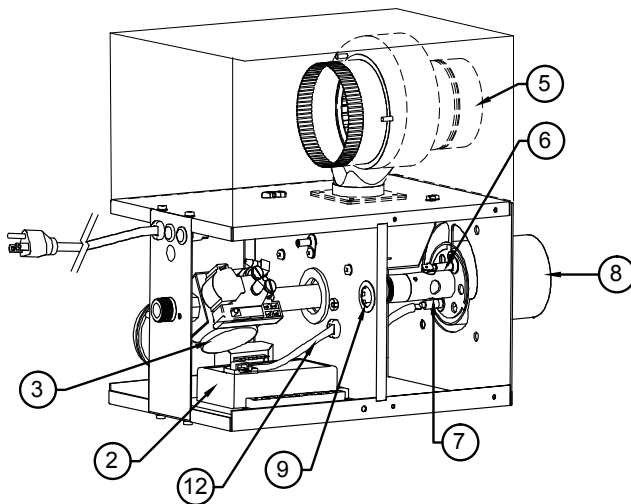

# REPLACEMENT PARTS

REFERENCE.	PART NUMBER.	DESCRIPTION
1	P-CE057	Indicator Light
2	P-CE015C	Ignition Module
3	P-CG142	Honeywell Valve Train Replacement Kit (NG)
	P-CG143	Honeywell Valve Train Replacement Kit (LPG)
4	P-CE058	Transformer
5	FA-CE133	Blower for Models 40,000 To 175,000 BTU
	FA-CE013	Blower for Models 205,000 To 220,000 BTU
6	P-CH007	Blower Gasket
7	P-CE003	Flame Sensor Electrode
8	P-CE002	Spark Electrode
9	P-CE006	Ignition Wire
10	P-UG001P	Burner Cup
	P-UG007	Burner Cup Assembly (C/W Electrodes)
11	P-CH011	Sight Glass Assembly
12	P-CE020	Air Switch - 40,000 & 60,000 BTU Models
	P-CE021	Air Switch - 80,000 & 100,000 BTU Models
	P-CE024	Air Switch - 125,000 & 150,000 & 205,000 BTU Models
	P-CE023	Air Switch - 220,000 BTU Models
	P-CE022	Air Switch - 175,000 BTU Models
13	P-CE010	Power Cord
14	P-CH001	Burner Gasket
15	V-VS022	Airline Kit



## THE ECONOMY RANGE WARRANTY

The manufacturer warrants to the original owner that the product will be free of defects in material and workmanship as described below.

ES/ESH Component	Warranty Period			
	3 Years	5 Years	7 Years	10 Years
Burner and Controls				
Hot Rolled Heat Exchanger w/o Post Purge				
Aluminized Heat Exchanger w/o Post Purge				
Hot Rolled Heat Exchanger with Post Purge				
Aluminized Heat Exchanger with Post Purge				

The Manufacturer's obligation under this warranty is limited to repair or replacement, F.O.B. its facility, of the defective part. In the case of replacement parts, the warranty period shall be the longer of the original warranty or a period of 12 months from the date of purchase. In no event shall the Manufacturer be liable for incidental expense or consequential damages of any kind.

This warranty does not cover any shipping, installation or other costs incurred in the repair or replacement of the product. No materials will be accepted for return without authorization.

This warranty will not apply if in the judgment of the Manufacturer, the equipment has been improperly installed, unreasonably used, damaged or modified.

This warranty will not apply to damage to the product when used in corrosive atmospheres and in particular atmospheres containing halogenated hydrocarbons. No person is authorized to assume for the Manufacturer any other warranty, obligation or liability.

THE REMEDIES PROVIDED FOR IN THE ABOVE EXPRESS WARRANTIES ARE THE SOLE AND EXCLUSIVE REMEDIES. NO OTHER EXPRESS OR IMPLIED WARRANTIES ARE MADE INCLUDING, BUT NOT LIMITED TO, ANY IMPLIED WARRANTY OF MERCHANTABILITY OR FITNESS FOR A PARTICULAR USE OR PURPOSE.





# ADVANCED RADIANT SYSTEMS

315 N Madison Street  
Fortville, IN 46040

317-577-0337  
800-874-3285

[sales@advancedradiantsystems.com](mailto:sales@advancedradiantsystems.com)

[www.AdvancedRadiantSystems.com](http://www.AdvancedRadiantSystems.com)

